

MITEL

5212/5224 IP Phones

SIP User and Administrator Guide
Release 3.0



NOTICE

The information contained in this document is believed to be accurate in all respects but is not warranted by Mitel Networks™ Corporation (MITEL®). The information is subject to change without notice and should not be construed in any way as a commitment by Mitel or any of its affiliates or subsidiaries. Mitel and its affiliates and subsidiaries assume no responsibility for any errors or omissions in this document. Revisions of this document or new editions of it may be issued to incorporate such changes.

Mitel is a registered trademark of Mitel Networks Corporation.

Internet Explorer is a trademark of Microsoft Corporation.

Netscape Navigator is a trademark of Netscape Communications Corporation.

Other product names mentioned in this document may be trademarks of their respective companies and are hereby acknowledged.

5212/5224 IP Phones SIP User and Administrator Guide Release 3.0

®,™ Trademark of Mitel Networks Corporation
© Copyright 2008 Mitel Networks Corporation
All rights reserved

TABLE OF CONTENTS

GETTING STARTED	1
SIP User Accounts and Passwords	1
SIP Administrative Mode	1
About Your SIP Phone.....	1
Elements of Your Phone	3
TIPS FOR YOUR COMFORT AND SAFETY	5
Don't cradle the handset!	5
Protect your hearing	5
Adjust the viewing angle	5
Call Encryption Indicator	6
Accessories for Your Phone	6
Headsets	6
Conference Units (5224 IP Phone only).....	6
Supporting Documentation	7
Accessing the Web Configuration Tool Online Help	7
Accessing Other Documentation.....	7
CUSTOMIZING YOUR PHONE.....	8
Superkey Menu Interface.....	8
Web Configuration Tool	8
Web Configuration Tool Accounts and Passwords.....	8
Accessing the Web Configuration Tool	9
Display-Assisted Feature Selection	9
Selecting Menu Options	9
Entering Numbers and Letters	9
Ringer Volume Control	10
Ringer Pitch Control.....	11
Handset Volume Control.....	11
Speaker Volume Control.....	11
Display Contrast Control.....	11
Display Language	11
Personal Keys.....	12
View Speed Dial Key Programming	13
Program a Speed Dial Key.....	13
Programming Features in Speed Dial Keys.....	14

Delete a Speed Dial Key	14
MAKING AND ANSWERING CALLS	15
Making Calls	15
Dial by Number.....	15
Dial by Name (5224 IP Phone only).....	15
Dial by SIP URL or IP Address (5224 IP Phone only)	15
Dial by Phone Book Entry	16
Dial by Call Logs Entry	16
Redial	16
Answering Calls	17
Answer a Call	17
Auto Answer	17
Answer a Call Waiting	17
Calling and Called Party Display	18
CALL HANDLING	19
Hold	19
Hold a Call.....	19
Retrieve a Call from Hold	19
Change On-Hold Settings	19
Call Forward	19
Program Call Forward	20
Enable/Disable Call Forward.....	20
Call Transfer	20
Transfer a Call to an Unconnected Third Party.....	21
Transfer a Call to a Third Party Already on Hold	21
Conference Call (Three-Way).....	21
Add a Third Party to a Call in Progress.....	21
Add a Party On Hold to a Call in Progress.....	22
Leave a Conference Call.....	22
Messages - Advisory	22
Create an Advisory Message	22
Enable/Disable your Advisory Message.....	22
Messaging – Voice Mail.....	23
Access your Voice Mail Messages.....	23
USING ADVANCED FEATURES	24
Do Not Disturb	24
Enable/Disable Do Not Disturb	24
Call Logs.....	24
View a Call Log Entry	25
Delete a Call Log Entry	25

Call a Call Logs Entry.....	25
Call Forking.....	25
Handset, Handsfree and Headset Modes.....	26
Switch between Handset and Handsfree	26
Switch between Handset and Headset	26
Switch between Headset and Handsfree	26
Muting a Call.....	26
Phone Book	27
Create a Phone Book Entry	27
Modify a Phone Book Entry.....	27
Delete a Phone Book Entry.....	28
Call a Phone Book Entry	28
Shared Lines and Keys.....	28
RSS (Web) Feed	29
Enable/Disable RSS Feed.....	29
Time and Date	30
Change the Time and Date	30
ADMINISTRATOR TOOLS	31
SIP Administrator Phone Passwords.....	31
Change Phone Passwords.....	31
SIP User Accounts.....	31
Configure/Modify a SIP User account.....	31
View a User Name	32
Device Parameters	32
Protocols.....	32
Enable/Disable Protocols	32
SRTP Call Encryption Indicator.....	33
Viewing/Modifying the Network Settings.....	33
View the IP and MAC Addresses	33
Modifying Network Settings.....	33
Upgrade the Phone's Firmware	34
View the Firmware Version	34
Upgrading the Firmware.....	34
Automating Firmware Upgrades	35
Using SIP Enhanced Mode.....	35
Configuring Voice Mail	36
Adjust Daylight Savings	36
Configuration Files.....	36
Hot Line	36

Media Configuration.....	37
Main Program and Boot Program Configuration Options	37
Global RSS Feed.....	37
SPECIFICATIONS.....	38
GLOSSARY.....	38

Getting Started

In SIP mode, the Mitel™ 5212 and 5224 IP Phones manage their own call states and features. SIP uses the Internet to connect your phone to other SIP phones. You can make calls on the Public Switched Telephone Network (PSTN), or “regular”, phone network. You can also call other SIP phones by dialing SIP URL or IP address. If you are registered with a SIP Service Provider, you may also be able to dial by user ID name or extension number.

In SIP Enhanced mode, your 5212 or 5224 IP Phone becomes a dedicated SIP phone with advanced features like shared lines: Bridged Line Appearances (BLA) in Sylanro environments and Shared Call Appearances (SCA) in Broadsoft environments. For more information about SIP Enhanced mode, refer to *Administrator Tools* on page 35. For information on how to program and change features on your SIP-supported phone, refer to this guide and to the Web Configuration Tool online Help (see *Supporting Documentation* on page 7).

SIP User Accounts and Passwords

Your Administrator usually configures SIP accounts for SIP phone Users and Administrators. You need a SIP User account in order to

- Register your phone with your SIP Service Provider
- Make calls by dialing a user ID name or extension number

If you do not have a SIP user account, you can still use your phone with limited access to SIP features and functionality.

SIP Administrative Mode

Administrators need an administrator user account and password to

- Modify network configuration settings and SIP Service Provider information
- Access SIP setting menus through the phone’s Superkey menu interface and Web Configuration Tool.

See *Administrator Tools* on page 31 for more information.

About Your SIP Phone

The 5212 and 5224 IP Phones have eight fixed-function keys and two arrow keys. The 5212 offers 12 personal keys, and the 5224 offers 24 personal keys for one-touch access to features. The 5212 and 5224 IP Phones offer display-assisted selection of features, on-hook dialing, handsfree speakerphone capability, and a large Ring/Message Indicator.

For more key and feature information, see *Elements of Your Phone* on page 3.

Figure 1: 5224 IP Phone



NN0192











Figure 2: 5212 IP Phone



NN0191

Elements of Your Phone

Each element is numbered according to the call-outs (e.g. ❶) in Figure 1 and Figure 2 on page 2. The 5212 IP Phone does not have softkeys.

Element	Function
❶ Display	<p>Two-line, 20-character liquid crystal display (LCD) viewing area for selecting and using phone features, accessing your voice mail, and identifying callers.</p> <p>Superkey menu options appear on the display screen.</p> <p>The stand built into your phone tilts to give you a better view of the display. To adjust the angle of the phone, refer to the <i>Installation Guide</i> shipped with your phone.</p>
❷ Softkeys (5224 IP Phone only)	Context-sensitive softkeys enable you to easily view and select features.
❸ Ring and Message Indicator	<p>Flashes to signal incoming calls and to indicate a message waiting in your voice mailbox.</p> <p>The indicator is ON solid while the phone reboots.</p>
❹ Volume, Speaker and Mute Controls	<p> (UP) and  (DOWN) arrow keys control display contrast and volume levels for the ringer, handset, and handsfree speakers.</p> <p>Arrows keys also allow you to change character (letter) input from upper or lower case and vice versa.</p> <p> (MUTE) toggles the microphone off and on. When it is ON, the microphone is OFF and your party cannot hear you.</p> <p> (SPEAKER) puts the phone in Handsfree operation.</p>
❺ Fixed-Function Keys	<ul style="list-style-type: none"> •  (SUPERKEY): provides access to the phone's menus. •  (CANCEL): ends a call, and eliminates any input and returns to the previous menu level during phone programming. •  (REDIAL): calls the last-dialed number, name, SIP URL, or IP address. •  (HOLD): places the current call on hold. •  (TRANS/CONF): initiates a call transfer or establishes a three-party conference call. •  (MESSAGE): accesses your voice mailbox (optional).
❻ Keypad	Use for dialing. On the 5212 IP Phone, use the keys *, 0 and # to select corresponding menu options shown on the display.
❼ Programmable Personal Keys and Designation Card	<p>Provide one-touch access to Speed Dial, Shared Lines, Call Logs, Headset, Phonebook, Do Not Disturb, and Advisory Message features.. See <i>Personal Keys</i> on page 12.</p> <p>Designation Card</p> <p>Write the name (contact, feature, or line) of the Personal keys that you program on the designation card (use the side of the card with the textboxes provided).</p> <p>Use the slot behind the plastic cover at the bottom of the phone to remove/insert the designation card.</p>

Element	Function
⑧ Speaker	Transmits audio during a Handsfree call.
⑨ Handset	Used for handset calls.

TIPS FOR YOUR COMFORT AND SAFETY

Don't cradle the handset!

Prolonged use of the handset can lead to neck, shoulder, or back discomfort, especially if you cradle the handset between your ear and shoulder. If you use your phone a lot, you may find it more comfortable to use a headset. See the section on headset usage elsewhere in this guide for more information.

Protect your hearing

Your phone has a control for adjusting the volume of the handset receiver or headset. Because continuous exposure to loud sounds can contribute to hearing loss, keep the volume at a moderate level.

Adjust the viewing angle

The stand built into your phone tilts to give you a better view of the keys.

To tilt your telephone for better viewing:

1. Turn the phone so that the front faces away from you.
2. Hold the base unit firmly and press the release tabs on the sides of the stand to detach the base unit.
3. Hinge the hooks of the base unit into the notches on the back of the phone and snap into place as follows:
 - a) For a high-angle mount, hinge the two lower hooks into the bottom set of notches and snap the two upper hooks into the middle set of notches.
 - b) For a low-angle mount, hinge the two lower hooks into the middle set of notches and snap the two upper hooks into the top set of notches.

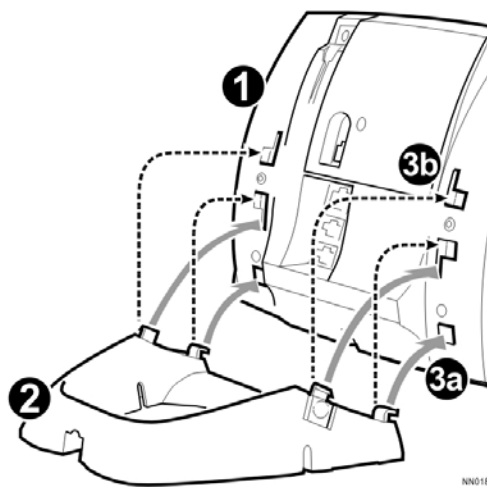

Call Encryption Indicator

The 5212 and 5224 IP Phones automatically provide Secure Real-time Transport Protocol (SRTP) voice encryption when connected to a phone that also supports SRTP. A “secured call” icon (closed padlock) appears on the display for encrypted calls, and for conference calls in which all connected parties support SRTP. An “unsecured call” icon (open padlock) appears on the display when the call connection is not secured (the connected party or parties do not support SRTP encryption). For an icon to appear, SRTP must be enabled. You can enable or disable SRTP on your phone using the Feature Configuration page of the Web Configuration Tool. (See *Accessing the Web Configuration Tool Online Help* on page 7.)

Note: The padlock icon appears only when you are speaking to a party; it does not appear if you receive a busy signal.

Accessories for Your Phone

Headsets

The 5212 and 5224 IP Phones support a Mitel-approved headset with a Feature Control Switch. Install the headset only in the dedicated headset jack on the back of the phone. Installation disables your handset microphone. Disconnecting the headset at the jack or at the quick-disconnect plug restores handset operation. If handset operation is required for an extended period of time, press the **Headset** key to return the phone to handset mode.

Conference Units (5224 IP Phone only)

Mitel SIP provides support for the 5310 IP Boardroom Conference Unit for use with the 5224 IP Phone. For more information about the conference unit, refer to the 5310 IP Boardroom Conference Unit documentation (see *Supporting Documentation* on page 7) or contact your Administrator.

Supporting Documentation

Accessing the Web Configuration Tool Online Help

To access programming instructions in the Web Configuration Tool online Help:

1. Access the Web Configuration Tool *Home Page* (see *Accessing the Web Configuration Tool* on page 9).
2. Scroll to the bottom of the page.
3. In the left pane, under **Support**, click **Help**. The Help page opens, presenting links to this guide and the User Web Configuration Tool online Help.

Note: If you have administrative privileges, you will have access to both the User and the Administrator Web Configuration Tool online Help systems.

Accessing Other Documentation

To access other Mitel phone and peripheral documentation:

1. In your browser, go to www.mitel.com
2. Click **Resources**
3. From the Documentation list, select **Guides** and then click User Guides.

Customizing Your Phone

To customize and use your phone features, use either of the following two interfaces:

- Superkey Menu Interface
- Web Configuration Tool

Superkey Menu Interface

The fixed-function keys provide access most features on your phone. The phone's Superkey menu interface provides access to additional features.

To access the Superkey menu interface, press the blue  (SUPERKEY).

Web Configuration Tool

The Web Configuration Tool is an optional tool that you can use in addition to your phone to make calls and to personalize and modify your phone settings.

With a SIP user account, you can access the Web Configuration from any personal computer (PC) connected to the Internet and running a web browser that is either

- Netscape Navigator 4.8 or later
- Internet Explorer 4 or later
- Any other equivalent browser.

Note: If your network is protected by a firewall, you may not be able to access your phone using the Web Configuration Tool from outside the firewall.

Web Configuration Tool Accounts and Passwords

You must have either a User or Administrator account to access the tool. Your account determines the type of web configuration pages you can access when you connect to the phone.

Your Administrator may change the default user name and password settings. If necessary, obtain your new user name and password from your Administrator.



Table 1: Web Configuration Tool Default User Names and Passwords

	Default User Name	Default Password (5212 IP Phone)	Default Password (5224 IP Phone)
User	user	hello	hello

Note: For Administrator default user name and password, see *Administrator Tools* on page 31.

Accessing the Web Configuration Tool

To access the Web Configuration Tool:

1. On your phone, do the following to obtain your phone's IP address:
 - Press  (**SUPERKEY**).
 - Press the **Line 1** (Prime Line) key. Your phone's IP address appears.
 - Write down the IP address, and then press  (**SUPERKEY**) to return to the default display.
2. On your PC, launch your browser.
3. In your browser's **URL** or **Address** field, enter your phone's IP address. The Web Configuration Tool login screen appears.
4. In the appropriate fields, enter your Web Configuration Tool user name and password.
5. Click **OK**. The Web Configuration Tool *Home Page* launches.

Note: If you are a SIP Administrator, see *Administrator Tools* on page 31 for administrative options.

Note: If you need help programming features, access the Web Configuration Tool online Help (see *Accessing the Web Configuration Tool Online Help* on page 7).

Display-Assisted Feature Selection

Selecting Menu Options

On a 5212 IP Phone, press *, **0** and # on the keypad to select menu items on the display. For example, if options * =YES **0**=DEFAULT #=NO appear and you want to select YES, press *.

On a 5224 IP Phone, press the softkeys to select menu items on the display.

Entering Numbers and Letters

5212 IP Phone

On the 5212 IP Phone, use the keypad to enter

- Extension numbers
- Phone numbers (PSTN numbers).

Note: When you are dialing an extension or phone number on a 5212 IP Phone (only), do not press the * and # keys. Press # to call the dialed number. Press * to delete the last-entered digit.

5224 IP Phone

Depending on the context, the 5224 IP Phone's keypad allows you to enter only numbers, or numbers, letters, and some special characters. On the 5224 IP Phone, you can dial

- Extension numbers
- Phone numbers (PSTN numbers)
- IP addresses



- SIP URLs
- User ID names.

Letters correspond to those on the keypad, and characters to the table below. A flashing cursor indicates the position of the character you are entering. The cursor automatically advances after one second, or if you press a different keypad key.

To enter letters and special characters:

- Rapidly press the appropriate number key until the desired character appears on the display.

To enter an uppercase letter:

- Press  (UP) before entering the letter. Press  (DOWN) to return to lowercase mode.

To delete the character last entered:

- Press the  softkey.

Table 2: Letter and Character Entry

Dial Pad Key	Press								
	Once	Twice	3 Times	4 Times	5 Times	6 Times	7 Times	8 Times	9 Times
1	1	space	?	!	~				
2	2	a	b	c					
3	3	d	e	f					
4	4	g	h	i					
5	5	j	k	l					
6	6	m	n	o					
7	7	p	q	r	s				
8	8	t	u	v					
9	9	w	x	y	z				
0	0	+	&	%	\$	\	"		
*	*	.	=	:	/	;	,	-	_
#	#	@	()	[]	<	>	



Ringer Volume Control

To adjust the ringer volume while your phone is ringing:

- Press  (UP) or  (DOWN).





To adjust the ringer volume on your phone while your phone is idle:

1. Press  (SUPERKEY), and then press >> until SETTINGS & OPTIONS? appears.
2. Press OK, and then press ▼ until RINGER SOUNDS? appears.
3. Press OK. SET RINGER VOLUME? appears.
4. Press YES. The phone rings.

5. Press  (UP) or  (DOWN) to adjust the volume to the desired level, and then press **SAVE**. SET RINGER VOLUME? appears.
6. Press **NO**. SET RINGER PITCH? appears.
7. Do one of the following:
 - To return to the main menu, press **NO**.
 - To return to the default display, press  (**SUPERKEY**).

Ringer Pitch Control

To adjust the ringer pitch on your phone:

1. Press  (**SUPERKEY**), and then press >> until SETTINGS & OPTIONS? appears.
2. Press **OK**, and then press  until RINGER SOUNDS? appears.
3. Press **OK**, and then press **NO** until SET RINGER PITCH? appears.
4. Press **YES**. The phone rings.
5. Press  (UP) or  (DOWN) to adjust the pitch to the desired level, and then press **SAVE**. SET RINGER PITCH? appears.
6. Do one of the following:
 - To return to the main menu, press **NO**.
 - To return to the default display, press  (**SUPERKEY**).

Handset Volume Control

To adjust the handset receiver volume when you are using the handset:

- Press  (UP) or  (DOWN).

Speaker Volume Control

To adjust the speaker volume when on a handsfree call:

- Press  (UP) or  (DOWN).

Display Contrast Control

To adjust the display contrast of your phone:

- Press  (UP) or  (DOWN) while the phone is idle.

Note: If your phone loses power, the settings will return to the default settings.

Display Language

To set the display language:

1. Press  (**SUPERKEY**), then press >> until SETTINGS & OPTIONS? appears.

2. Press **OK**, and then press ▼ until LANGUAGE? appears.
3. Press **OK**, and then press **NO** until the desired language appears.
4. Once the desired language appears, press **YES**. LANGUAGE? appears on the display.
5. Do one of the following:
 - To return to the main menu, press **EXIT**.
 - To return to the default display, press  (**SUPERKEY**).

Personal Keys

Personal keys provide one-touch access to the following features:

- Speed Dial
- Shared Lines
- Line Keys (Administrator only)
- Call Logs
- Phonebook
- Forwarding
- Do Not Disturb
- Advisory Message
- PC Application (if applicable)
- Headset on/off
- RSS Feed (Web Feed)
- HTML Application

You can program any Personal key that isn't a prime line key. For example, you can program a Speed Dial key for one-touch dialing. You can also view, modify, or delete the information programmed on any Personal key except Line 1 and Line 2.

Note: You cannot change your **Personal** keys settings while on a call.

Note: You can use the Web Configuration Tool to easily program, edit, and delete programmable key information. For key programming settings, instructions, and phone layouts, refer to the *About the Key Programming Page* topic in the *Advanced Features* section of the Web Configuration tool online help. Also see [Using Advanced Features](#) on page 24. Instructions for programming personal keys using the phone itself are supplied in the following sections.

For information about programming shared line keys, see *Shared Lines and Keys* on page 28.

Line Keys

Line keys allow you to make and answer calls according to line or caller information. The 5224 IP Phone has four Line keys. The 5212 IP Phone has two Line keys. If one line is busy, incoming calls are received on the next available Line key. Each phone has a pre-assigned prime line (Line 1) key.

Pre-assigned Personal Keys

Your SIP phone has the following pre-assigned personal keys that cannot be changed:

Pre-assigned Value	Key Location (Count from the bottom to top on the 5212 IP Phone, and from the bottom to top in the right row on the 5224 IP Phone)
Line Keys (1 = Prime Line)	Key 1 - 4
Headset on/off	Key 10
Advisory Message	Key 11
Call Logs	Key 12

View Speed Dial Key Programming

To view the current programming on a Personal key:

1. Press  (**SUPERKEY**), and then press **>>** until PROGRAM MEMORY KEYS? appears.
2. Press **OK**. SELECT A KEY appears.
3. Press a **Personal** key. If the key is programmed, the programming information appears. If the key is not programmed, UNUSED KEY appears.

Program a Speed Dial Key

To program a **Personal** key as a Speed Dial key:

1. Press  (**SUPERKEY**), and then press **>>** until PROGRAM MEMORY KEYS? appears.
2. Press **OK**. SELECT A KEY appears.
3. Press the **Personal** key you wish to program. The associated programming information appears on the display. If the key is not programmed, UNUSED KEY appears.
4. Do one of the following:
 - If the selected key is currently programmed, press **DEL** (on a 5212) or **DELETE** (on a 5224) or **EDIT**. ENTER NUMBER appears.
 - If the selected key is currently programmed as a different feature key, press **MDFY TO SPEEDDIALKEY** to modify the key to a Speed Dial key. ENTER NUMBER appears.
 - If the selected key is not currently programmed, press **ADDNEW**. ENTER NUMBER appears.
5. Do one of the following:
 - If you want to enter a name, press **NAME**.
 - (5224 IP Phone only) If you want to enter a SIP URL or an IP address, press **URL**.

Note: Press **<** to delete characters.
6. Enter the destination information, and then press **SAVE**. KEY SAVED appears.
7. Press **OK**. PROGRAM MEMORY KEYS? appears.

8. Do one of the following:
 - To program additional Speed Dials, press **OK**. **SELECT A KEY** appears.
 - To return to the default display, press  (**SUPERKEY**).
9. Write the feature name on the designation card (see *Elements of Your Phone* on page 3).

Note: If the number you are calling requires an intermediate Long Distance Carrier number to be dialed before the phone number, you can program a Speed Dial number for the Carrier. After pressing the Speed Dial number for the carrier, wait for connection to the Carrier. When connected, press the Speed Dial number for the party you are calling to send the DTMF (touchtone signals) to the Carrier.



Note: If the Speed Dial number you want to program requires pauses (for example, if you normally dial a main number, wait for a prompt, and then dial an extension) you can program them into a Speed Dial key by entering a comma to represent a one-second pause. For example, to dial main number 592-2122 and then enter extension 111 after a 3-second pause, program a Speed Dial number as follows: 5922122,,,111

Programming Features in Speed Dial Keys

For Sylanro and Broadworks deployments, you can program any feature access codes that require additional user input as Speed Dial keys. To access the feature directly, simply enter the feature access code (for example, *67) as the Speed Dial number. To access the feature and then have the phone wait for your manual input, enter the feature access code followed by a semi-colon (for example, *67;)

Delete a Speed Dial Key

To delete a Speed Dial key:

1. Press  (**SUPERKEY**), and then press >> until **PROGRAM MEMORY KEYS?** appears.
2. Press **OK**. **SELECT A KEY** appears.
3. Press the **Personal** key whose programming you want to delete. The associated programming appears.
4. Press **DEL** (on a 5212) or **DELETE** (on a 5224). **DELETE ITEM?** appears.
5. Press **YES**. **UNUSED KEY** appears.
6. Do one of the following:
 - To return to the main menu, press **EXIT**.
 - To return to the default display, press  (**SUPERKEY**).

Making and Answering Calls

Making Calls

You can make and receive calls using the handset, headset or handsfree speaker. You can dial by extension number or phone number, user ID name (5224 IP Phone only), SIP URL or IP address (5224 IP Phone only), or IP address. You can also dial a Call Logs or Phonebook entry.

If you are registered with a SIP Service Provider and want to dial a “regular” phone number, your SIP Service Provider must provide access to the PSTN. To dial a SIP user name or extension number, you must be registered with a SIP Service Provider. For more information, contact your Administrator.

Dial by Number

1. Lift the handset (optional).
2. If you want to use a line other than **Line 1**, press a **Line** key.
3. Do one of the following:
 - Dial the number.
 - Press a **Speed Dial** key.
 - Press **123**  (**REDIAL**). (See [Redial](#) on page 16.)
4. Press **DIAL or # (the pound key)**.

Dial by Name (5224 IP Phone only)

To dial by a user ID name, you must be registered with a SIP Service Provider.

1. Lift the handset (optional).
2. Press **NAME**.
3. Enter the name of the party you want to call.

Note: If the name has more than 20 characters, only the last 20 characters appear on the display.



4. Press **DIAL or # (the pound key)**.

Dial by SIP URL or IP Address (5224 IP Phone only)

1. Lift the handset (optional).
2. Press **URL**, then enter the SIP URL or IP address of the party you want to call.



Note: If the SIP URL exceeds 20 characters, only the last 20 characters appear.
3. Press **DIAL or # (the pound key)**.

Dial by Phone Book Entry



1. Press  (**SUPERKEY**), and then press >> until PHONE BOOK? appears.
2. Press **OK**. PHONE BOOK <number of items> appears on the display.
3. Press  (**UP**) and  (**DOWN**) to navigate to the entry you want to call.
4. Press **DIAL or # (the pound key)**.
5. Lift the handset (optional).

Note: To dial from your Phone Book using the Web Configuration Tool, access the tool's *Phone Book* page (see *Accessing the Web Configuration Tool* on page 7).

Dial by Call Logs Entry

1. Press  (**SUPERKEY**), and then press >> until CALL LOGS? appears.
2. Press **OK**, and then press ▼ to navigate to the desired log type (Missed Calls, Answered Calls or Outgoing Calls).
3. Press **OK**. The number of calls appears.
4. Press  (**UP**) and  (**DOWN**) to navigate through the logged call entries.
5. Press **DIAL or # (the pound key)**. The log is dialed and the phone returns to the default display.
6. Lift the handset (optional).

Redial

1. Lift the handset (optional).
2. Press  (REDIAL). The last number you dialed appears in the display.
3. Do one of the following:
 - Press the right-hand softkey to dial this number (5224 only).
 - Press  (REDIAL) to scroll the list of previously-dialed numbers and then press the right-hand softkey to dial when the desired number is displayed.

Note: The redial list is maintained even after the phone reboots and is updated periodically. If a power failure occurs during the update, it is possible that one or more previously-dialed numbers may be lost.

Answering Calls

Incoming calls ring **Line 1**, if all lines are free, or the next available line. If all lines are busy and Call Forward – Busy is not enabled (see *Enable/Disable Call Forward* on page 20), callers hear a busy signal.

When the phone rings, the Ring/Message Indicator and the associated **Line** key flash, and the name of the caller appears in the information area.

Answer a Call

To answer a call, do one of the following:

- For handset mode, lift the handset.
- For headset mode, press the **Headset** key, then press the flashing **Line** key.
- For handsfree mode, press  (**SPEAKER**) or press the flashing **Line** key.

For more information on handset, handsfree (Speaker) or headset calls, see *Handset, Handsfree and Headset Modes* on page 26.

Auto Answer

You can use Auto Answer to automatically answer incoming calls in handsfree or headset mode.

To enable or disable Auto Answer:

- Access the *Feature Configuration* page of the Web Configuration (see *Accessing the Web Configuration Tool* on page 7).

To answer an Auto Answer call:

- Begin speaking when the call arrives.

To end an Auto Answer call, do one of the following:

- Press  (**CANCEL**).
- Wait for the caller to hang up.

Answer a Call Waiting

The 5224 IP Phone allows a maximum of three calls waiting while you are on a call. The 5212 IP Phone allows one call waiting. New calls wait on the next free line. When a new call arrives, you hear a call waiting tone, the name of the new caller appears, and the corresponding **Line** key flashes. If all lines are busy, callers hear a busy signal.

To answer a waiting call:

- Press the flashing **Line** key of the call waiting. The current call is put on hold, and you are connected to the new caller.

To return to the original call:

- Press the associated flashing **Line** key.

Calling and Called Party Display

SIP phones display the true (programmed) identity of the called/calling party rather than the standard number/name display.

Call Handling

Hold

The 5224 IP Phone supports a maximum of four held calls at the same time. The 5212 IP Phone supports a maximum of two held calls.

When you place a call on hold, or when another party puts you on hold, the on-hold beep reminds you that you are holding or on hold. If the handset is in its cradle, you hear the beep through the handsfree speaker. You can turn off this beep, if desired.

Note: You cannot change your hold settings while on a call.

Hold a Call

- Press  (HOLD). The associated **Line** key flashes.

Retrieve a Call from Hold

- Press the associated flashing **Line** key. The **Line** key changes from flashing to lit solid.

Change On-Hold Settings

- Access the *Feature Configuration* page of the Web Configuration (see *Accessing the Web Configuration Tool* on page 7).

Call Forward

Call Forward redirects incoming calls to your voice mailbox (by default) or to an alternate number. Choose from the following Call Forward options:



- **Call Forward – Always** redirects all incoming calls
- **Call Forward – No Answer** redirects calls if you don't answer after the programmed number of rings (1 – 10)
- **Call Forward – Busy** redirects calls when all lines are busy.

All Call Forward options are OFF by default. You can turn on Call Forward No Answer and Call Forward Busy at the same time.



Note: You cannot change your Call Forward settings while on a call.

Note: To program and enable or disable Call Forward using the Web Configuration Tool, access the tool's *Feature Configuration* page (see *Accessing the Web Configuration Tool* on page 7).

Program Call Forward

1. Press  (**SUPERKEY**), and then press >> until SETTINGS & OPTIONS? appears.
2. Press **OK**. CALL FORWARDING? appears.
3. Press **OK**. FWD ALWAYS: <current status> appears.
4. Press ▼ to navigate to the desired Call Forward option.
5. Press **OK** to select the desired Call Forward option.
6. Press **REVIEW**. The current forwarding destination appears. If no forwarding is programmed, the top line of the display is blank.
7. For **Call Forward No Answer** option only, press **OPTIONS**, enter the number of desired rings (1 – 10) before a call is forwarded, and then press **SAVE**.
8. Press **CHANGE**, and then do one of the following:
 - To enter a URL as the destination, press **URL**, and then enter the URL.
 - To enter a name as the destination, press **NAME**, and then enter the name.
9. Press **SAVE**. After the information is saved, the same Call Forwarding option appears on the display with its new status. Note: You can disable this display using the Display Control section of the Feature Configuration page of the Web Configuration Tool.
10. Do one of the following:
 - To return to the main menu, press **EXIT**.
 - To return to the default display, press  (**SUPERKEY**).

Enable/Disable Call Forward





1. Press  (**SUPERKEY**), and then press >> until SETTINGS & OPTIONS? appears.
2. Press **OK**. CALL FORWARDING? appears.
3. Press **OK**. FWD ALWAYS: <current status> appears.
4. Press ▼ to navigate to the desired Call Forward option.
5. Once the desired Call Forwarding option appears, press **TURNON** or **TURNOFF** to enable or disable the Call Forwarding option. The Call Forwarding option and its new status appears on the display.
6. Press **OK**, and then press  (**SUPERKEY**) to return to the default display.

Call Transfer



You can transfer an active call to another party (one line must be free on your phone). The 5224 IP Phone supports four lines. The 5212 IP Phone supports two lines. If all lines are busy on your phone, no calls can be transferred.

Note: During a conference call, any party can perform a call transfer when one line on the phone that initiated the conference call is not in use. For conference call information, see *Conference Call (Three-Way)* on page 21.

Transfer a Call to an Unconnected Third Party

1. While on a call, press  (TRANS/CONF). The call is put on hold.
2. Press a free **Line** key.
3. Call the party to whom you want to transfer the call, and then do one of the following:
 - To talk to this party, wait until the connection is established, speak to the party, press  (TRANS/CONF) or press the **TRANSFR** softkey (5224 only), and then hang up. This is an Attended Call Transfer.
 - To transfer the call without speaking to this party, immediately press  (TRANS/CONF) or press the **TRANSFR** softkey (5224 only), and then hang up. The held call will be transferred to the call in progress. This is an Unattended Call Transfer.
 - To cancel the transfer, press  (CANCEL). You are returned to the held call.

Transfer a Call to a Third Party Already on Hold

1. While on a call, press  (TRANS/CONF). The call is put on hold.
2. Press the **Line** key of the call on hold, and then press  (TRANS/CONF).
3. Hang up.



Conference Call (Three-Way)

When two parties are connected on a call, either of those parties can originate a three-way conference by adding a third party to the call in progress. Once three parties are connected, no more parties can be added to that call.

A party can be involved in more than one three-way conference call at a time, but the calls cannot be merged. For example, A and B are on a call. A adds C to create three-way conference call ABC. B adds D to the call with A to make conference call ABD. ABC and ABD remain separate— D is not added to conference call ABC.



Note: During a conference call, any party can perform a call transfer when one line on the phone that initiated the conference call is not in use. For call transfer information, see *Call Transfer* on page 20.

Add a Third Party to a Call in Progress

1. Press  (TRANS/CONF). The current call is put on hold.
2. Press a free **Line** key, and then do one of the following:
 - Dial the number.
 - Press a **Speed Dial** key.
 - Press  (REDIAL).
3. Press **DIAL**.
4. Press the **CONF** softkey (or the # to select **CONF** on the 5212). The call you put on hold in step 1 is connected to the call in progress.

Note: If the new party does not answer, press  (**CANCEL**) twice to return to the held party.

Add a Party On Hold to a Call in Progress

1. Press  (**TRANS/CONF**). The current call is put on hold.
2. Press the **Line** key of the party already on hold.
3. Press  (**TRANS/CONF**). The call put on hold in step 1 is connected to the call in progress.

Leave a Conference Call

Do one of the following:

- Hang up.
- Press **HANGUP** softkey (5224 IP Phone only).
- Press  (**CANCEL**).

Note: If the party who initiated the conference call hangs up, the other two parties are also disconnected. If either of the called parties hangs up, the call remains connected.

Messages - Advisory





An advisory message about your whereabouts appears on your caller's display.

Create an Advisory Message

- Access the *Feature Configuration* page of the Web Configuration Tool (see *Accessing the Web Configuration Tool* on page 7).

Enable/Disable your Advisory Message

To enable or disable an advisory message:

1. Press  (**SUPERKEY**), and then press >> until **SETTINGS & OPTIONS?** appears.
2. Press **OK**, and then press ▼ until **ADVISORY MESSAGES?** appears.
3. Press **OK**. The first of several advisory messages appears.
4. Press  (**UP**) or  (**DOWN**) to navigate to the desired message.
5. Press **TURNON** or **TURNOFF** to enable or disable the message. When turned on, the **Advisory Message** key is lit.
6. Do one of the following:
 - To return to the main menu, press **EXIT**.
 - To return to the default display, press  (**SUPERKEY**). The advisory message alternates with the date and time on the default display.

Note: To enable/disable advisory messages using the Web Configuration Tool, access the tool's *Feature Configuration* page (see page 7).

Messaging – Voice Mail

Your Administrator configures your voice mail information so you can receive and access voice mail messages. The Ring/Message Indicator flashes to indicate waiting messages.

Note: For administrative information on voice mail, see *Voice Mail* on page 35.

Access your Voice Mail Messages

1. Lift the handset (optional).
2. Press  (**MESSAGE**) and enter your voice mailbox number.
3. Follow the voice mailbox prompts.



Using Advanced Features

Do Not Disturb

Do Not Disturb (DND) forwards all calls directly to your voice mailbox so that a ringing phone will not disturb you. If Do Not Disturb is enabled and you do not have a voice mailbox set up, callers hear a busy signal.

Note: When Do Not Disturb is enabled, ***DND ON*** alternates with the date on the phone's display. If both Call Forward and Do Not Disturb are on, ***DND ON*** alternates with the time on the display. Note: You can disable this display using the Display Control section of the Feature Configuration page of the Web Configuration Tool.

Enable/Disable Do Not Disturb

1. Press  (**SUPERKEY**), and then press >> until SETTINGS & OPTIONS? appears on the display.
2. Press **OK**, and then press ▼ until DO NOT DISTURB? appears.
3. Press **OK**. DO NOT DISTURB <current status> appears.
4. Press **TURNON** or **TURNOFF** to enable or disable Do Not Disturb. After the information is saved, DO NOT DISTURB <new status> appears.
5. Do one of the following:
 - To return to the main menu, press **EXIT**.
 - To return to the default display, press  (**SUPERKEY**).

Note: To enable or disable Do Not Disturb using the Web Configuration Tool, access the tool's *Feature Configuration* page (see *Accessing the Web Configuration Tool* on page 7).





Call Logs

Call Logs keeps a record of your missed, answered and outgoing calls. The 5212 IP Phone logs the five most recent missed, answered, and outgoing calls. The 5224 IP Phone logs the ten most recent missed, answered, and outgoing calls. The most recent call appears at the top of each log.

Call Logs record party name, number, SIP URL or IP address, the call duration, and the time and date of each call. When you have missed incoming calls, the number of calls missed replaces the date on your phone's display. Note: You can disable this display using the Display Control section of the Feature Configuration page of the Web Configuration Tool.

Note: Call log information is saved automatically every 4 hours. If you reset your phone in that 4-hour interval, any call logs generated during that time will not be stored.





View a Call Log Entry

1. Press  (**SUPERKEY**), and then press >> until CALL LOGS? appears.
2. Press **OK**, and then press ▼ to navigate to the desired log type (Missed Calls, Answered Calls or Outgoing Calls).
3. Press **OK**. The number of calls appears.
4. Press  (**UP**) and  (**DOWN**) to navigate through the logged call entries.
5. When the desired entry appears, press **DETAIL**, and then press << and >> to view the entry information.
6. When you have finished, press **DONE**.
7. Press  (**SUPERKEY**) to return to the default display.

Note: To view Call Log entries using the Web Configuration Tool, access the tool's Call Logs page (see *Accessing the Web Configuration Tool* on page 7).

Delete a Call Log Entry

Note: You can delete all entries in a Call log using the **Delete All** button on the Call Logs page of the Web Configuration tool.

1. To delete selected entries in a call log: Press  (**SUPERKEY**), and then press >> until CALL LOGS? appears on the display.
2. Press **OK**, and then press ▼ to navigate to the desired log type (Missed Calls, Answered Calls or Outgoing Calls).
3. Press **OK**. The number of calls appears.
4. Press  (**UP**) and  (**DOWN**) to navigate through the logged call entries.
5. When the desired entry appears, press **DELETE**. CONFIRM DELETE? appears.
6. Press **YES**. The log is deleted.
7. Press  (**SUPERKEY**) to return to the default display.

Call a Call Logs Entry

- See Dial by Call Logs Entry on page 16 to quickly dial a Call Logs entry.

Call Forking

You can register your SIP ID with several SIP sets and have all configured sets ring simultaneously. The indicator lamps of all configured aliases will flash until the call is answered, and then all lamps except the answering set are extinguished. All Mitel SIP phones support call forking.

Handset, Handsfree and Headset Modes

Switch between Handset and Handsfree

To go from handset to handsfree mode:

1. Press  (**SPEAKER**).
2. Hang up the handset. Use the handsfree speaker to communicate with your party.

To go from handsfree to handset mode:

- Lift the handset, and use it to communicate with your party.

Switch between Handset and Headset

To go from handset to headset mode:

1. Press the **Headset** key. The **Headset** key light turns ON.
2. Hang up the handset. Use the headset to communicate with your party.

To go from headset to handset mode:

1. Lift the handset.
2. Press the **Headset** key. The **Headset** key turns OFF. Use the handset to communicate with your party.

Switch between Headset and Handsfree

To go from headset to handsfree mode:

- Press the **Headset** key, and then press  (**SPEAKER**). The **Headset** key turns OFF. Use the handsfree speaker to communicate with your party.

To go from handsfree to headset mode:



- Press the **Headset** key. The **Headset** key turns ON. Use your headset to communicate with your party.

Muting a Call

To mute your phone so your party cannot hear you:

- Press  (**MUTE**). The  (**MUTE**) key turns ON.

To turn Mute off and return to the conversation:

- Press  (**MUTE**) again. The  (**MUTE**) key turns OFF.

Phone Book





The Phone Book is a scrollable list of contacts from which you can make a call. The 5212 IP Phone holds a maximum of 20 Phone Book contacts. The 5224 IP Phone holds a maximum of 60 Phone Book contacts.

Phone Book entries contain an automatic index number, the contact's name (maximum of 20 characters) and a number, SIP URL, or IP address.





Note: To create, modify, or make calls from your Phone Book using the Web Configuration Tool, access the tool's *Phone Book* page (see *Accessing the Web Configuration Tool* on page 7).

Note: You cannot change your Phone Book settings while on a call.





Create a Phone Book Entry

1. Press  (**SUPERKEY**), and then press >> until PHONE BOOK? appears.
2. Press **OK**. PHONE BOOK: <number of items> appears.
3. Press  (**UP**) and  (**DOWN**) to navigate through the entries until ENTRY EMPTY appears.
4. Press **ADDNEW**. PROGRAM ADDRESS? appears.
5. Press **YES**, and then enter the IP address or SIP URL of the contact.
Note: Press <— to delete characters.
6. Press **SUBMIT**. After the information is saved, PROGRAM NAME? appears.
7. Press **YES**, and then enter the name of the contact.
8. Press **SUBMIT**. After the information is saved, the name of the contact appears.
9. Press  (**SUPERKEY**) to return to the default display.

Modify a Phone Book Entry

1. Press  (**SUPERKEY**), and then press >> until PHONE BOOK? appears.
2. Press **OK**. PHONE BOOK: <number of items> appears.
3. Press  (**UP**) and  (**DOWN**) to navigate to the entry you want to modify.
4. Press **CHANGE**, and then press **EDIT**. PROGRAM ADDRESS? appears.
5. Do one of the following:
 - To modify an address or a SIP URL, press **YES**, enter the address or SIP URL, and then press **SUBMIT**. After the information is saved, PROGRAM NAME? appears.
 - To modify a name, press **NO**. PROGRAM NAME? appears. Press **YES**, enter the name, and then press **SUBMIT**. After the information is saved, the modified name appears.
6. Press  (**SUPERKEY**) to return to the default display.

Delete a Phone Book Entry

1. Press  (**SUPERKEY**), and then press >> until PHONE BOOK? appears.
2. Press **OK**. PHONE BOOK: <number of items> appears.
3. Press  (**UP**) and  (**DOWN**) to navigate to the entry you want to delete.
4. Press **CHANGE**, and then press **DELETE**. CONFIRM DELETE? appears.
5. Press **CONFIRM**. The entry is deleted, and ENTRY EMPTY appears.
6. Press  (**SUPERKEY**) to return to the default display.

Call a Phone Book Entry

- See *Dial by Phone Book Entry* on page 16 to call a Phone Book entry

Shared Lines and Keys

There are three types of shared lines:

- **SIP**: basic shared line with limited features (supports call forking but does not have LED activity and lines are not linked. This type of shared line is available in normal SIP mode).
- **SIP_BLA line type**: server-enhanced Sylanro Bridged Line Appearance line type
- **SIP_SCA line type**: server-enhanced Broadworks Shared Call Appearance line type

BLA and SCA line types allow calls and lines to be shared by multiple users. A SIP server provides support for call presentation to multiple phones, call state notifications, and access control. These two line types require the set to be in SIP Enhanced mode. (See *SIP Enhanced Mode* on page 35.)

The SIP Enhanced mode shared lines are shared among users but only the user who initiates activity on the line has full control over it. For example, if a user initiates a conversation on a shared line, other users can not affect that conversation. If the shared line is Ringing, or on Hold, any share user can pick up the line and be connected to the calling/held party.

An exception to this scenario occurs when the server is configured to allow line seizure by multiple lines. Mitel SIP phones support multi-call server programming.

Requirements for making calls and picking up held calls from shared lines are the same as normal (non-shared) lines.

Shared Line Programming Requirements:

- Your Administrator must create a user entry (on the User List Config page of the Web Configuration tool) for the user with whom you want to share a line.
- Your Administrator must configure the type of shared line (SIP, BLA, or SCA) in the **Line Type** field on the **User List Config** page.
- Your Administrator must enable SIP Enhanced mode (on the Advanced Features page) before **SIP_BLA** and **SIP_SCA** modes can be configured.

Programming Shared Line Keys

1. Access the **Key Programming** page of the Web Configuration Tool.
2. Click the **Key Number** of the key you want to assign as a shared line.
3. From the **Feature** list, select **Shared Line**.
4. From the **Context** list, select the User ID with which to associate this key.
5. Enter a label/description for this key (optional).
6. Click **Apply** to apply the changes.

Line Key Status

Shared lines display the following indicator lamps:

Line Status	LED Appearance	Description
Trying	Solid Red	When a user initiates a call on a shared line, the LED of that line and all shared lines glows red.
Active	Solid Green	When a call has been successfully connected, the LED of that line and all shared lines glows green.
Held	Flashing Red	When a user puts another party on hold, the LED of that line and all shared lines flashes red.
Alerting	Flashing Green	When a call is incoming, the LED of the called line and all shared lines flashes green.

RSS (Web) Feed

RSS feeds are text formats used to deliver information such as News and weather reports. Your Mitel SIP Phone can act as an RSS feed reader, displaying the feed on Line 1 of the phone display when the phone is idle. You can program one or more keys on your phone to display a web feed or to display your own customized message (branding). Use the Key Programming Page in the Web Configuration Tool to program one or more RSS Feed keys. For more information, refer to the Web Configuration Tool Online Help.

Enable/Disable RSS Feed

Once an RSS Feed key is programmed, press the key to display the feed. The LED on the key will light up and remain lit while the RSS feed scrolls continuously across Line 1 of your phone display. Press the key again to stop the feed.

Note: If your Administrator has programmed a global RSS feed or branding message for your phone, this text will be displayed when your phone is idle. When one of your own personal RSS Feed keys is enabled, it will override any global feed set by your Administrator for your phone.

Tip: To improve RSS readability, you can disable other displays (like Call Forwarding and Missed Calls). Use the Feature Configuration page of the Web Configuration Tool to set Display Controls.

Time and Date

A Simple Network Time Protocol (SNTP) server (version 4 or later) provides your phone with the date and time. Your Administrator configures your time zone once using the Web Configuration Tool. Your phone automatically adjusts to Daylight Savings.



If an SNTP server is not available in your system setup, you can modify the time and date using your phone or the *Date/Time* page of the Web Configuration Tool (see *Accessing the Web Configuration Tool* on page 7). For more information, contact your Administrator.

Note: You cannot change your time and date settings while on a call.

Note: If your phone loses power, the modified time and date are not saved.

Change the Time and Date

Important: Use this procedure only if an SNTP server is not provided. If an SNTP server is not available, you must reprogram these settings every time the phone reboots.

1. Press  (**SUPERKEY**), and then press >> until SETTINGS & OPTIONS? appears.
2. Press **OK**, and then press ▼ until TIME AND DATE? appears.
3. Press **OK**. SET TIME? appears.
4. Do one of the following:
 - To change the time, press **YES**. 12 OR 24 HR FORMAT? appears. Proceed to step 5.
 - To change the date, press **NO**. SET DATE? appears. Proceed to step 9.
5. Do one of the following:
 - To enter the time in a.m./p.m. format, press **12**.
 - To enter the time using the 24-hour clock, press **24**.
6. Enter the time (for example, 1236 for 12:36; 0220 for 02:20), and then press **SUBMIT**.
7. (For a.m./p.m. only) Press **AM** or **PM**. SET TIME? appears with the new time.
8. Press **NO**. SET DATE? appears.
9. Do one of the following:
 - To change the date, press **YES**, and then proceed to step 10.
 - To return to the main menu, press **NO**, and then proceed to step 11.
10. Enter the date (for example, enter 161204 for 16 December 2004), and then press **SUBMIT**. SET DATE? appears with the new date.
11. Do one of the following:
 - To return to the main menu, press **NO**.
 - To return to the default display, press  (**SUPERKEY**).

Administrator Tools

This section is the SIP Administrator's reference to Superkey menu interface configuration options. Where applicable, it references the appropriate page(s) of the Web Configuration Tool.

Note: Some procedures can only be completed from the Web Configuration Tool.

To access the referenced pages of the Web Configuration Tool, see *Accessing the Web Configuration Tool* (page 7).

To get help with settings and programming for administrative procedures, see *Accessing the Web Configuration Tool Online Help* (page 7).

SIP Administrator Phone Passwords

To log in for the first time as an Administrator, use the default administrator name and password. Change these passwords as soon as possible to prevent unauthorized changes to the phone.

For privacy reasons, an asterisk (*) appears for each character you enter.

Table 3: Default Administrator User Names and Passwords

Phone	Default Administrator Name	Default Administrator Password
5212 IP Phone	admin	5212
5224 IP Phone	admin	5224

Change Phone Passwords

To change user or administrator passwords:

- Access the *Users & Passwords* page of the Web Configuration Tool.



SIP User Accounts

A SIP user account includes a user name and password, and allows the user to register with the SIP Service Provider.

Configure/Modify a SIP User account



Access the *Configuring Users and SIP Server Providers* topic in the Administrator's Web Configuration Tool online help.

View a User Name

1. Press  (**SUPERKEY**).
2. Press the third **Personal** key (counting upwards from the bottom on the 5212 IP Phone) or the **Line 3** key (counting upwards from the bottom right on the 5224 IP Phone). The user display name (top) and user name (bottom) appears.
3. Press  (**SUPERKEY**) to return to the default display.

Device Parameters

To view the software version and the MAC address:

1. Press  (**SUPERKEY**), and then press **>>** until ADMIN TOOLS? appears on the display.
2. Press **OK**. DEVICE PARAMETERS? appears.
3. Press **OK**. SOFTWARE VERSION appears.
4. View either the software version or the MAC address.
 - To view the software version, press **REVIEW** (the current software version appears), then press **OK**. SOFTWARE VERSION reappears.
 - To view the MAC address, press **NEXT** (MAC ADDRESS appears), then press **REVIEW**. The current MAC address appears. Press **OK**. MAC ADDRESS reappears.
5. Do one of the following:
 - To return to the main menu, press **EXIT**.
 - To return to the default display, press  (**SUPERKEY**).

Note: You can also view the MAC address using the **Line 1** key (see *View the IP and MAC Addresses* on page 33).

Protocols

For information about supported communication and media protocols, access the *Configuring Protocols* topic of the Administrator's *Web Configuration Tool* Online (see *Accessing the Web Configuration Tool Online Help* on page 7).

Enable/Disable Protocols

To enable/disable protocols using the Web Configuration Tool:

- Access the tool's *Protocols* page.

Note: To access the Web Configuration Tool, HTTP must be enabled. If HTTP is disabled and you need to access the tool, enable HTTP through the Superkey Menu Interface (see procedure that follows below).

To enable/disable protocols using the Superkey Menu Interface:

1. Press  (**SUPERKEY**), and then press **>>** until ADMIN TOOLS? appears on the display.

2. Press **OK**, and then press **▼** until ACCESS PROTOCOLS? appears on the display.
3. Press **OK**, enter your administrator password, and then press **SUBMIT**. HTTP <current status> appears on the display.
4. Do one of the following:
 - To enable HTTP, press **TURNON**.
 - To disable HTTP, press **TURNOFF**.
 - To enable or disable TFTP, press **NEXT**.
5. Repeat steps 3 and 4 for TFTP, Telnet, SNMP and SRTP. After you enable or disable a protocol, that protocol and its new status appears on the display.
6. Do one of the following:
 - To return to the main menu, press **EXIT**.
 - To return to the default display, press  (**SUPERKEY**).



SRTP Call Encryption Indicator

For information about the Call Encryption setting, see Call Encryption Indicator on page 6. Also refer to the *Configuring Protocols* topic of the Administrator's *Web Configuration Tool* Online Help (see page 7).

Viewing/Modifying the Network Settings

View the IP and MAC Addresses

To view the phone's IP and MAC addresses:

1. Press  (**SUPERKEY**), and then press the **Line 1** key. The IP and MAC addresses appear.
2. Press  (**SUPERKEY**) to return to the default display.

Modifying Network Settings

To modify network settings using the Web Configuration Tool:

- Access the *Configuring Network Settings* topic of the Administrator's Web Configuration Tool online help.

To modify network settings using the Superkey Menu Interface

1. Press  (**SUPERKEY**), and then press **>>** until ADMIN TOOLS? appears on the display.
2. Press **OK**, and then press **▼** until NETWORK SETTINGS? appears.
3. Press **OK**, enter your administrator password, and then press **SUBMIT**.
4. Press **NEXT** until the network configuration settings you want to change appear.
5. Press **REVIEW** to view the current settings of the selected setting, and then do one of the following:

- (Optional) To enable or disable DHCP, press **TURNON** or **TURNOFF**.
 - To change a value, press **CHANGE**, enter the new value, and then press **SUBMIT**. After the information is saved, the next setting appears.
 - To leave a value as it is, press **EXIT** or **NEXT**.
6. Repeat steps 4 and 5 until all desired changes have been made.
 7. Press  (**SUPERKEY**) to return to the default display.
 8. For the settings to take effect, reboot the phone (i.e. unplug the power source from the phone, and then plug the power source back in).

Upgrade the Phone's Firmware

IMPORTANT: If you are upgrading from a previous load, please ensure you are following the correct upgrade procedure as outlined in the latest product Release Notes available from the SIP Software Download Page. The SIP Software Download Page provides access to the latest SIP firmware loads, upgrade procedures, and Release Notes.

To access the latest SIP firmware loads, upgrade procedures, and Release Notes:

1. In your browser, go to www.mitel.com, click **Login**, and log in to Mitel OnLine.
2. Move your cursor over **Products and Services**, and select **SIP Desktop Devices**.
3. In "Related Links" click **SIP Software Download Page** for firmware loads or **Product Documentation** to access the SIP documentation.

For detailed information about firmware upgrades:



- Access the *About the Firmware Updates Page* topic in the Administrator's *Web Configuration Tool* Online Help (see page 7).

View the Firmware Version

To view the firmware version using the Web Configuration Tool:

- Access the *Home Page* of the Web Configuration Tool and click **Firmware Updates**.

To view the firmware version using the Superkey Menu Interface:

4. Press  (**SUPERKEY**).
5. Press the **Line 2** key. Both the main and boot firmware versions appear on the display.
6. Press  (**SUPERKEY**) to return to the default display.

Upgrading the Firmware

To upgrade the firmware using the Web Configuration Tool:

- Access the *Configuring Network Settings* and *Updating Firmware* sections of the Administrator's Web Configuration Tool.

To upgrade the phone's firmware through the Superkey Menu Interface:

1. Press  (**SUPERKEY**), and then press **>>** until **SETTINGS & OPTIONS?** appears.
2. Press **OK**, and then press **▼** until **UPGRADE FIRMWARE?** appears.

3. Press **OK**. CHOOSE PROTOCOL appears.
4. Press the desired protocol (**HTTP** or **TFTP**), or press **AUTO**. BEGIN UPGRADE NOW? appears.
5. Press **CONFIRM**. The downloading process begins and the phone reboots. This process may take approximately 1 to 2 minutes. When the time and date appear on the display, the download and reboot is complete and the phone is ready for use.

CAUTION: DO NOT remove power from the phone while firmware is downloading or the phone is rebooting. This may result in severe damage to your phone.

 **Troubleshooting Tip:** If your phone displays "SIP MAIN NOT FOUND", it is likely that your system has experienced a power failure. The SIP Phone Boot firmware "borrows" Flash sectors from the SIP Main area during firmware installation. At the end of a normal installation, the sectors are restored without affecting SIP Main. However, if power is removed during Boot installation, then SIP Main is erased and will have to be reinstalled on the phone.

Automating Firmware Upgrades

You can configure phones to poll the server for new versions of firmware. When the phone detects a firmware upgrade, it downloads the new version and stores it in memory. When it is next idle, the phone reboots with the new firmware.

To automate firmware upgrades, your Administrator can set a Firmware Upgrade option and a polling interval on the Firmware Update page of the Web Configuration Tool. For programming options, refer to the online help supplied with the Web Configuration Tool.

To upgrade firmware on multiple phones, refer to the *Mass Deployment* topic in the Administrators Tools section of the Web Configuration Tool Online Help.

Using SIP Enhanced Mode

SIP Enhanced mode enables your 5212/5224 phone to support server-enhanced shared lines including Sylanro Bridged Line Appearance (BLA) and Broadsoft Shared Call Appearance (SCA).

Note: After you enable SIP Enhanced mode on a phone, it becomes a dedicated SIP phone. You can not toggle back to MiNET mode.

To enable SIP Enhanced mode:

1. From the Web Configuration Tool home page, click **Advanced Features**.
2. In the SIP Enhanced Mode list, select **On**.
3. Click **Save and Reboot**.

To enable SIP Enhanced mode in the Boot program, refer to *Configuring Network Settings > Configuring in the Main and Boot Programs > Boot Program Menu Options* in the Web Configuration Tool online help.Voice Mail

Voice mail for SIP-supported phones is server-based. For more information on the voice mail system, contact the SIP Service Provider.



To configure voice mail on the 5212 IP Phone and 5224 IP Phone:

- Access the *Administrator Tools > Configuring SIP Features* section in the Administrator's Web Configuration Tool online help.

Use the procedure below for configuring voice mail on a 5224 IP Phone only.

Configuring Voice Mail

To configure voice mail (on a 5224 IP Phone only):

1. Press  (**SUPERKEY**), and then press >> until ADMIN TOOLS? appears.
2. Press **OK**, and then press ▼ until NETWORK SETTINGS? appears.
3. Press **OK**, enter your administrator password, and then press **SUBMIT**.
4. Press **NEXT** until VOICE MAIL SERVER appears, and then press **REVIEW**.
5. Press **CHANGE**, enter the IP address of the voice mail server, and then press **SUBMIT**. After the information is saved, VOICE MAIL SERVER appears.
6. Press **NEXT**. VOICE MAIL PORT NUM appears.
7. Press **REVIEW**, and then press **CHANGE**.
8. Enter the voice mail port number, and then press **SUBMIT**. After the information is saved, VOICE MAIL PORT NUM appears.
9. Do one of the following:
 - To return to the main menu, press **EXIT**.
 - To return to the default display, press  (**SUPERKEY**).

Adjust Daylight Savings

Access the *Administrator Tools > Configuring Network Settings* topic in the Administrator's Web Configuration Tool online help.

Configuration Files

The 5212 and 5224 IP Phones support configuration files for automatic programming. For more information about the configuration files, and about configuring multiple phones, access the *Administrator Tools > Phone Management* topic in the Administrator's Web Configuration Tool online help.

Hot Line

When a Hot Line number, SIP URL or an IP address is set up, the 52125 or 5224 IP Phone automatically dials that number or address when taken off-hook.

For Hot Line programming instructions, access the *Administrator Tools > Configuring SIP Features* section in the Administrator's Web Configuration Tool online help.

Media Configuration

For programming instruction, access the *Administrator Tools > Configuring Media Settings* topic in the Administrator's Web Configuration Tool online help.

Main Program and Boot Program Configuration Options

For information about additional configuration options available through the phone's main program (Superkey menu interface) or boot program:

- Access the *Administrator Tools > Configuring in the Main and Boot Programs* topic in the Administrator's *Web Configuration Tool* online Help.

Global RSS Feed

You can program a global RSS feed or branding message that will be displayed on Line 1 of Mitel SIP Phones when the phones are idle. Program the global RSS feed in the *Advanced Features* section of the Web Configuration Tool. For more information, refer to the Web Configuration Tool Online Help.

Specifications

For a complete list of supported features (including Sylanro and Broadsoft features) and supported RFCs, access the *Specifications* topic in the Web Configuration Tool online help.

Glossary

Term	Definition
DHCP	Dynamic Host Configuration Protocol
HTTP	Hypertext Transfer Protocol
ICP	Integrated Communications Platform
ID	Identification
IP	Internet Protocol
LAN	Local Area Network
MAC	Media Access Control
PSTN	Public Switched Telephone Network
RSS	Really Simple Syndication
SIP	Session Initiation Protocol
SNMP	Simple Network Management Protocol
SNTP	Simple Network Time Protocol
SRTP	Secure Real-time Transport Protocol
TFTP	Trivial File Transfer Protocol
URL	Uniform Resource Locator
VLAN	Virtual LAN



Global Headquarters	U.S.	EMEA	CALA	Asia Pacific
Tel: +1(613) 592-2122 Fax: +1(613) 592-4784	Tel: +1(480) 961-9000 Fax: +1(480) 961-1370	Tel: +44(0)1291-430000 Fax: +44(0)1291-430400	Tel: +1(613) 592-2122 Fax: +1(613) 592-7825	Tel: +852 2508 9780 Fax: +852 2508 9232

For more information on our worldwide office locations, visit our website at www.mitel.com/offices

THIS DOCUMENT IS PROVIDED TO YOU FOR INFORMATIONAL PURPOSES ONLY. The information furnished in this document, believed by Mitel to be accurate as of the date of its publication, is subject to change without notice. Mitel assumes no responsibility for any errors or omissions in this document and shall have no obligation to you as a result of having made this document available to you or based upon the information it contains.

M MITEL (design) is a registered trademark of Mitel Networks Corporation. All other products and services are the registered trademarks of their respective holders.
© Copyright 2008, Mitel Networks Corporation. All Rights Reserved.

www.mitel.com

