

MITEL

# 5220 | IP Phone

USER GUIDE

 **MITEL** | it's about **YOU**





# Contents

<b>ABOUT YOUR PHONE</b>	<b>1</b>
Using the 5220 IP Phone in Remote Mode	3
About Feature Access Codes	3
For Users on Resilient 3300 ICP Systems	3
<b>TIPS FOR YOUR COMFORT AND SAFETY</b>	<b>4</b>
Don't cradle the handset!	4
Protect your hearing	4
Adjusting the viewing angle	4
<b>CUSTOMIZING YOUR PHONE</b>	<b>5</b>
Ringer Control	5
Handset Receiver Volume Control	6
Speaker Volume Control	6
Display Contrast Control	6
Feature Keys	6
Language Change	7
<b>MAKING AND ANSWERING CALLS</b>	<b>7</b>
Make a call	7
Answer a call	7
Phonebook	8
Redial	8
Redial - Saved Number	8
Speed Call Keys	9
Speed Call - Personal	10
Handsfree Operation	11
Auto-Answer	12

<b>CALL HANDLING</b>	<b>12</b>
Hold	12
Transfer	13
Conference	13
Conference Split	13
Add Held	14
Swap	14
Call Forward	15
Call Forward - Remote	16
Call Forward - End Chaining	16
Call Forward - Forced	17
Call Forward - Override	17
Messaging - Advisory	17
Messaging - Callback	18
Messaging - Cancel Callback	19
Messaging - Cancel All Callbacks	19
<b>USING ADVANCED FEATURES</b>	<b>20</b>
Account Codes	20
Call Park	20
Call Pickup	20
Campon	21
Do Not Disturb	21
Override	21
Paging	21
Direct Paging	22
Reminder	23
Headset Operation	23
Headset Operation (with Feature Control Switch)	24
Music	24
Group Paging / Meet Me Answer	25
Trunk Flash	25
Record a Call	26
Hot Desking	27
Tag Call	28

## ABOUT YOUR PHONE

The MITEL NETWORKS 5220IP phone has ten fixed-function keys ( **SUPERKEY, TRANS/CONF, REDIAL, MESSAGE, HOLD, CANCEL, SPEAKER, MICROPHONE, , ** ), three softkeys, and 14 personal keys with built-in status indicators. The personal key on the bottom right is always your Prime Line; the remaining personal keys can be programmed as:

- Feature keys (for example, Swap). You can program feature keys from your phone or using the Desktop Tool. Your administrator can also program feature keys.
- Speed Call keys. You can program speed call keys from your phone, or using the Desktop Tool.
- Line Appearances. Only the administrator can program line appearances.

**Note:** For more information on the Desktop Tool, talk to your system administrator.

Your phone also features display-assisted selection of features, on-hook dialing, and a large Message Indicator.

**Note:** When using the **SuperKey**, press **Cancel** to back up one menu level.

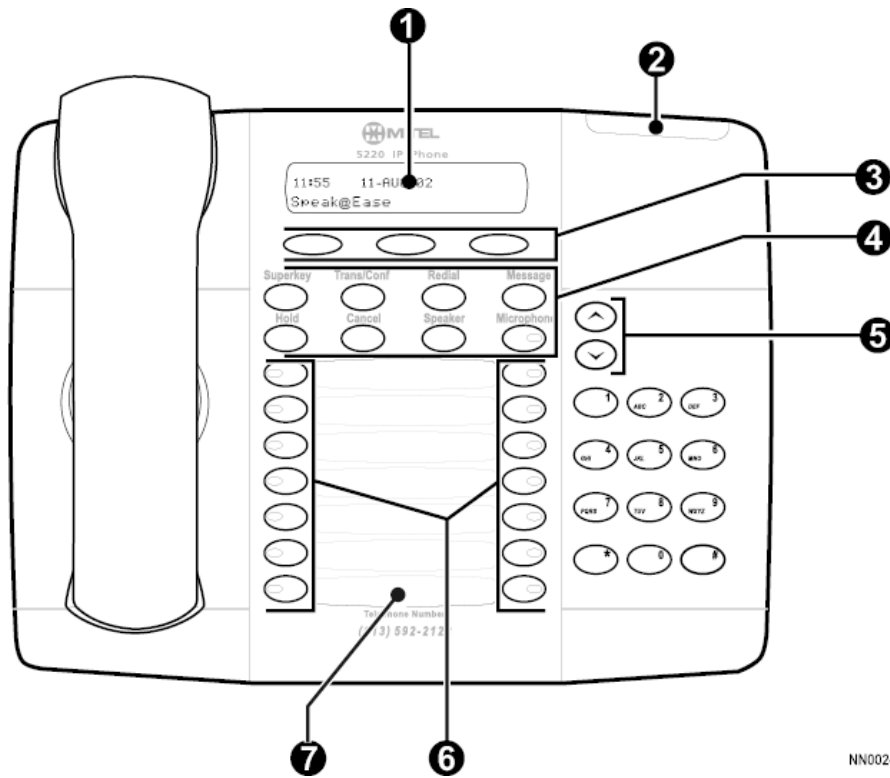

NN0024

1. Display
2. Message Waiting Indicator
3. Softkeys
4. Fixed-Function Keys
5. Volume Control
6. Programmable Feature Keys

## **IMPORTANT NOTE FOR HEADSET USERS:**

Mitel Networks Headsets with Feature Control Switch must be installed in the dedicated headset jack (the jack nearest the front of the set). Installation will disable your handset microphone. Disconnecting the headset at the jack or at the quick-disconnect plug restores handset operation.

### *Telephone status indicators*

<b>When line is</b>	<b>the indicator is</b>
Idle	Off
Busy	On
Ringing	Flashing slowly
On hold at your phone	Flashing rapidly
On hold at another phone	Flashing slow on/fast off

## **Using the 5220 IP Phone in Remote Mode**

Remote Mode allows the 5220 IP Phone to be used in the home or in other locations away from the office. For information on how to program the 5220 IP Phone for remote operation, refer to the *Remote IP Phones Guide* available at [www.mitel.com](http://www.mitel.com)

## **About Feature Access Codes**

Use of some features requires dialing access codes. The codes are flexible and may be different than those in this guide. Ask your Administrator for a list of codes you should use.

## **For Users on Resilient 3300 ICP Systems**

If during a call, you hear two beeps repeated every 20 seconds it means that your phone is switching to a secondary 3300 ICP system. The call continues but the keys and features on your phone stop working. The keys and most features begin working again after you hang up. Normal operation resumes when your phone switches back to the primary system. If your phone is idle and switched to the secondary system, you'll see a flashing rectangle on the display. The rectangle remains until the switch to the primary system is complete.

# TIPS FOR YOUR COMFORT AND SAFETY

## **Don't cradle the handset!**

Prolonged use of the handset can lead to neck, shoulder, or back discomfort, especially if you cradle the handset between your ear and shoulder. If you use your phone a lot, you may find it more comfortable to use a headset. See the section on headset usage elsewhere in this guide for more information.

## **Protect your hearing**

Your phone has a control for adjusting the volume of the handset receiver or headset. Because continuous exposure to loud sounds can contribute to hearing loss, keep the volume at a moderate level.

## **Adjusting the viewing angle**

The stand built into your phone tilts to give you a better view of the keys.

*To tilt your phone for better viewing:*

1. Press the release tabs on these sides of the stand.
2. Hinge the two front hooks and snap the two back hooks of the stand into either the upper or lower notches on the back of the phone.



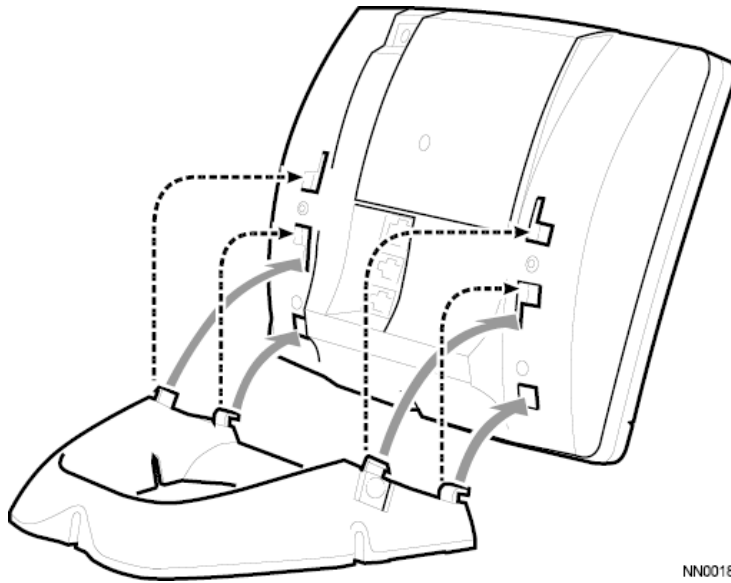

NN0018



## CUSTOMIZING YOUR PHONE

### Ringer Control

*To adjust the Ringer Volume while the phone is ringing:*

- Press , .

*To adjust the Ringer Pitch while the phone is idle:*

1. Press **SUPERKEY**.
2. Press the **No** softkey until "Ringer Adjust?" appears.
3. Press the **Yes** softkey.
4. Press the **Yes** softkey.
5. Press , .
6. Press **SUPERKEY**.

## Handset Receiver Volume Control

*To adjust the Handset Receiver Volume when you are using the handset:*

- Press , .

## Speaker Volume Control

*To adjust the Speaker Volume when making an on-hook call or when listening to background music:*

- Press , .

## Display Contrast Control

*To adjust the Display Contrast while your phone is idle:*

- , .

## Feature Keys

You can use the **SUPERKEY** on your phone or the Desktop Tool to program the personal keys. The Desktop Tool is a browser-based interface that makes programming quick and easy.

For more information on using the Desktop Tool, please contact your System Administrator.

*To display information about a key:*

1. Press **SUPERKEY**.
2. Press a personal key or **REDIAL**.
3. Press **SUPERKEY**.

*To re-program a personal key:*

1. Press **SUPERKEY**.
2. Press the **No** softkey until "Personal Keys?" appears.
3. Press the **Yes** softkey.
4. Press a personal key that isn't a line key.
5. Press the **Change** softkey.
6. Press the **No** softkey until the desired feature appears.
7. Press the **Yes** softkey.
8. Press **SUPERKEY**.

## Language Change

*To change the display language:*

1. Press **SUPERKEY**.
2. Press the **No** softkey until "Language?" appears.
3. Press the **Yes** softkey.
4. Press the **Change** softkey.
5. Press the **No** until the desired language appears.
6. Press the **Yes** softkey.

## MAKING AND ANSWERING CALLS

### Make a call

1. Lift the handset.
2. If you want to use a Non-Prime Line, press a Line Appearance key.
3. Dial the number,  
-OR-  
Press a Speed Call key.  
-OR-  
Press **REDIAL**.

### Answer a call

- Lift the handset.  
-OR-  
Press the flashing Line appearance key and lift the handset.

## Phonebook

For each letter in the name, press the appropriate key on the keypad until the letter is shown in the display; for example, if the letter C is required, press the digit 2 three times. Use the ← softkey to correct errors. If the next letter in a name is on the same key as the previous letter, press the → softkey before proceeding. If required, use the → softkey to add a space between the first and last name.

*To use Phonebook:*

1. Press the **Phonebook** softkey.
2. Enter the name of the desired party.
3. Press the **Lookup** softkey.
4. If no match exists, edit the original entry.
5. If the name is not unique, press the **Next** softkey.
6. Do one of the following:
  - To make the call, press the **Call** softkey.
  - To edit the entry, press the **Retry** softkey.
  - To exit, press **SUPERKEY**.

## Redial

*To redial the last number that you manually dialed:*

1. Lift the handset.
2. Press **REDIAL**.

## Redial - Saved Number

*To save the last number that you manually dialed:*

1. Lift the handset.
2. Dial **\*\*79**.

*To Redial a saved number:*

1. Lift the handset.
2. Dial **\*6\***.

## Speed Call Keys

You may use Speed Call Keys to make a call or to send a string of digits during a call (press a Speed Call Key during a call to send a multi-digit password, for instance).

*To dial a stored Speed Call number:*

1. Lift the handset.
2. Press a Speed Call key.

*To store a Speed Call number:*

1. Press **SUPERKEY**.
2. Press the **No** softkey until "Personal Keys?" appears.
3. Press the **Yes** softkey.
4. Press a personal key that isn't a line key.
5. Press the **Change** softkey.
6. Press the **Yes** softkey.
7. Do one of the following:
  - To enter a new number, dial the number. Press **HOLD** between digits to create a pause during dialing; press **HOLD** more than once to lengthen the pause.
  - To enter a trunk flash, press **TRANS/CONF**. (See "Trunk Flash" for more information about the use of this feature.)
  - To enter the last number dialed, press **REDIAL**.
8. If you want the number to be private, press the **Priv** softkey.
9. Press the **Save** softkey.
0. Press **SUPERKEY**.

## **Speed Call - Personal**

*To dial a stored personal Speed Call number:*

1. Lift the handset.
2. Dial **58**.
3. Enter an index number between **00** and **09**.

*To store a personal Speed Call number:*

1. Lift the handset.
2. Dial **67**.
3. Enter an index number between **00** and **09**.
4. Dial the number to be stored (press **Hold** between digits to create a pause during dialing - press **Hold** more than once to lengthen the pause).
5. Hang up.

## Handsfree Operation

*To use Handsfree Operation to make calls:*

1. If you want to use a Non-Prime Line, press a Line Appearance key.
2. Dial the number.
3. Communicate by using the speaker and the microphone.

*To use Handsfree Operation to answer calls:*

1. Press the flashing line key.
2. Communicate by using the speaker and the microphone.

*To hang up while using Handsfree Operation:*

- Press **SPEAKER**.

*To temporarily disable the microphone during Handsfree Operation:*

- Press **MICROPHONE** (the microphone LED turns off).

*To re-enable the microphone and return to the conversation:*

- Press **MICROPHONE** (the microphone LED turns on).

*To disable Handsfree Operation:*

- Lift the handset.

*To return to Handsfree Operation:*

1. Press **SPEAKER**.
2. Hang up.

## **Auto-Answer**

*To enable or disable Auto-Answer:*

1. Press **SUPERKEY**.
2. Press the **No** softkey until "Auto Answer?" appears.
3. Do one of the following:
  - To enable Auto-Answer, press the **TurnOn** softkey.
  - To disable Auto-Answer, press the **TurnOff** softkey.

*To answer a call when you hear ringback:*

- Communicate by using the speaker and the microphone.

*To terminate a call:*

- Press **CANCEL**.
- OR-
- Wait for the caller to hang up.

## **CALL HANDLING**

### **Hold**

*To place a call on Hold:*

- Press **Hold**.

*To retrieve a call from Hold:*

1. Lift the handset.
2. Press the flashing line key.

*To retrieve a call from Hold at another station:*

- Press the flashing line key.
- OR-
- Dial **\*\*1** and the number of the station that placed the call on Hold.



## Transfer

*To Transfer an active call:*

1. Press **TRANS/CONF**.
2. Dial the number of the third party.
3. Do one of the following:
  - To complete the Transfer, hang up.
  - To announce the Transfer, wait for an answer, consult, and hang up.
  - To cancel the Transfer, press **CANCEL**.

*To transfer an active call during headset operation:*

1. Press **TRANS/CONF**.
2. Dial the number of the third party.
3. To complete the Transfer, press the **Release** feature key.

## Conference

*To form a Conference when a two-party call is already in place, or to add another party to an existing Conference:*

1. Press **TRANS/CONF**.
2. Dial the number of the next party.
3. Wait for an answer.
4. Press **TRANS/CONF**.

*To leave a Conference:*

- Hang up.

## Conference Split

*To Split a Conference and speak privately with the original party:*

- Press the **Split** softkey.

## **Add Held**

*To move a call on Hold to another line appearance:*

1. Press the available line key.
2. Press the **Addheld** softkey.
3. Press the flashing line key.

*To add a call on Hold to an existing conversation or conference:*

1. Press the **Addheld** softkey.
2. Press the flashing line key.

## **Swap**

*To call another party when you are in an established two-party call:*

1. Press **TRANS/CONF**.
2. Dial the number.

*To alternate between the two parties:*

- Press the **Trade** softkey.

## Call Forward

Call Forward lets you redirect incoming calls to an alternate number. Always redirects all incoming calls regardless of the state of your phone. B-Int redirects internal calls when your phone is busy, and B-Ext redirects external calls when your phone is busy. NA-Int redirects internal calls after several rings if you don't answer, and NA-Ext redirects external calls after several rings if you don't answer.

**Note:** For information about "I'm Here?", see Call Forward - Remote.

*To program Call Forward:*

1. Press **SUPERKEY**.
2. Press the **No** softkey until "Call Forwarding?" appears.
3. Press the **Yes** softkey.
4. Press the **Next** softkey until the type of Call Forward appears (see above).
5. Press the **Review** softkey.
6. If a number is already programmed, press the **Change** softkey.
7. Press the **Program** softkey.
8. Dial the destination number.
9. Press the **Save** softkey.

*To turn Call Forward on and off (once it has been programmed):*

1. Press **SUPERKEY**.
2. Press the **No** softkey until "Call Forwarding?" appears.
3. Press the **Yes** softkey.
4. Press the **Next** softkey until the type of Call Forward appears.
5. Press the **Review** softkey.
6. Press the **Change** softkey.
7. Do one of the following:
  - To turn Call Forward on, press the **TurnOn** softkey.
  - To turn Call Forward off, press the **TurnOff** softkey.

## **Call Forward - Remote**

*To forward calls from a remote station to your current location:*

1. Press **SUPERKEY**.
2. Press the **No** softkey until "Call Forwarding?" appears.
3. Press the **Yes** softkey.
4. Press the **Next** softkey until "I Am Here" appears.
5. Press the **Yes** softkey.
6. Dial the extension of the remote station.
7. Press the **Save** softkey.

*To cancel Call Forward - Remote from the station that set the remote forwarding:*

1. Lift the handset.
2. Dial **\*\*77**.
3. Dial the extension of the remote station.
4. Hang up.

*To cancel Call Forward - Remote from the station that was forwarded:*

1. Press **SUPERKEY**.
2. Press the **No** softkey until "Call Forwarding?" appears.
3. Press the **Yes** softkey.
4. Press the **Review** softkey.
5. Press the **Change** softkey.
6. Press the **TurnOff** softkey.
7. Press **SUPERKEY**.

## **Call Forward - End Chaining**

*To ensure that calls do not get forwarded again by the destination number:*

1. Lift the handset.
2. Dial **64**.
3. Hang up.

*To again allow calls to be forwarded by the destination number:*

1. Lift the handset.
2. Dial **\*\*73**.
3. Hang up.

## **Call Forward - Forced**

*To force an incoming call to be forwarded:*

- Press the **Forward** softkey.

## **Call Forward - Override**

*To override Call Forward and ring a station:*

1. Lift the handset.
2. Dial **\*1\***.
3. Dial the extension number.

## **Messaging - Advisory**

*To turn Messaging - Advisory on:*

1. Press **SUPERKEY**.
2. Press the **No** softkey until "Advisory Msgs?" appears.
3. Press the **Yes** softkey.
4. Press the **Next** softkey until the desired message appears.
5. Press the **TurnOn** softkey.

*To turn Messaging - Advisory off:*

1. Press **SUPERKEY**.
2. Press the **No** softkey until "Advisory Msgs?" appears.
3. Press the **Yes** softkey.
4. Press the **TurnOff** softkey.

## **Messaging - Callback**

*To leave a message waiting indication on a phone when you hear busy or ringback tone:*

- Press **MESSAGE** or the **Callback** softkey.

*To respond to a message waiting condition on your phone:*

1. Press **MESSAGE**.
2. If a password is required, dial your password and press the **Enter** softkey.
3. Press the **Yes** softkey.
4. Do one or all of the following (if required):
  - To display the time the message was sent, press the **More** softkey.
  - To display the number of the caller, press the **More** softkey twice.
5. Do one of the following:
  - To call the message sender, press the **Call** softkey.
  - To delete the message, press the **Erase** softkey.
  - To view the next message, press **MESSAGE**.

*To check for messages from a remote station:*

1. Press **SUPERKEY**.
2. Press the **No** softkey until "Remote Msging?" appears.
3. Press the **Yes** softkey.
4. Dial your extension number.
5. Press the **Enter** softkey.
6. If a password is required, enter your password and press the **Enter** softkey.
7. Press the **Yes** softkey.

*To set, change, or clear a password (up to 7 digits, not including 0):*

1. Press **SUPERKEY**.
2. Press the **No** softkey until "Set Password?" appears.
3. Press the **Yes** softkey.
4. Do one of the following:
  - To enter a new password, enter your password.
  - To change or clear your password, enter your current password.
5. Press the **Enter** softkey.
6. If you are changing or clearing your password, do one of the following:
  - To change your password, enter your new password and press the **Enter** softkey.
  - To clear your password, enter **0**.
7. Enter your new password again.
8. If you are setting up or changing a password, press the **Enter** softkey.
9. Press **SUPERKEY**.

## **Messaging - Cancel Callback**

*To cancel a Callback:*

1. Lift the handset.
2. Dial **\*1#**.
3. Dial the number of the called station.
4. Hang up.

## **Messaging - Cancel All Callbacks**

*To cancel all Callbacks:*

1. Lift the handset.
2. Dial **#1**.
3. Hang up.

# USING ADVANCED FEATURES

## Account Codes

*To use Forced Account Codes:*

1. Lift the handset.
2. Dial the Account Code digits.
3. Press **#**.

*To enter an Account Code during a call:*

1. Press **SUPERKEY**.
2. Press the **Yes** softkey.
3. Dial the Account Code digits.
4. Press the **Save** softkey.
5. Do one of the following:
  - For a verified account code, press the **Yes** softkey.
  - For a non-verified account code, press the **No** softkey.

## Call Park

*To retrieve a call parked by the attendant:*

1. Lift the handset.
2. Dial **\*23**.
3. Dial the console ID and the Hold Slot number.

## Call Pickup

*To answer a call that is ringing at another station in your Pickup Group:*

1. Lift the handset.
2. Press the **Pickup** softkey.

*To answer a call that is ringing at a station not in your Pickup Group:*

1. Lift the handset.
2. Dial **\*\*6**.
3. Dial the number of the ringing station.



## Campon

*To Campon to a busy station:*

- Press the **Wait** softkey.

*To retrieve a call when you hear Campon tone:*

- Press the **Trade** softkey.

## Do Not Disturb

*To activate or deactivate Do Not Disturb:*

- Press the **Do Not Disturb** feature key.

*To activate Do Not Disturb from a remote station:*

1. Lift handset.
2. Dial **\*\*5**.
3. Dial the number of the station to which **Do Not Disturb** is to apply.
4. Hang up.

*To deactivate Do Not Disturb from a remote station:*

1. Lift handset.
2. Dial **##5**.
3. Dial the number of the station with **Do Not Disturb** activated.
4. Hang up.

## Override

*To use Override when you encounter busy or DND tone:*

- Press the **Intrude** feature key.

## Paging

*To use Paging:*

1. Lift handset.
2. Press the **Pager** feature key.
3. Dial the Paging zone number (if required).
4. Make the announcement.

## Direct Paging

Direct Paging allows you to page a party through their phone speaker. If the paged party has Off-Hook Voice Announce enabled, the page will be heard even when the party is on a handset or headset call.

*To page a party:*

1. Lift the handset.
2. Press the **Direct Paging** feature key.
3. Dial the extension number.
4. Speak to the dialed party after the tone.

If Handsfree Answerback has been turned on at your phone and you receive a Direct Page while your phone is idle, or while you are on a handset or headset call, a handsfree call will automatically be established after a single burst of tone.

The following instructions assume that Handsfree Answerback is not enabled on your phone.

*To answer a Direct Page (indicated by a single burst of tone):*

- Lift handset.

- OR -

Press **MICROPHONE**.

*To answer a page while using the handset:*

- Press **MICROPHONE**.

*To enable or disable Handsfree Answerback:*

- Press **MICROPHONE** while the phone is idle.

## Reminder

*To program a Reminder:*

1. Press **SUPERKEY**.
2. Press the **No** softkey until "Timed Reminder?" appears.
3. Press the **Yes** softkey.
4. Enter the time in 24-hour format.
5. Press the **Save** softkey.

*To view, change, and/or cancel a pending Reminder:*

1. Press **SUPERKEY**.
2. Press the **No** softkey until "Timed Reminder?" appears.
3. Press the **Yes** softkey.
4. Do one of the following:
  - To change the Reminder, press the **Change** softkey, enter the new time, and press the **Save** softkey.
  - To cancel the Reminder, press the **Clear** softkey.
  - To exit without canceling the Reminder, press **SUPERKEY**.

*To acknowledge a Reminder when your phone rings once:*

- Press the **Confirm** softkey.

## Headset Operation

*To enable Headset Operation:*

- Press the **Headset** feature key.

*To answer a call (when Auto Answer is disabled):*

- Press the flashing line key.

*To hang up:*

- Press **CANCEL**.

*To disable Headset Operation:*

- Press the **Headset** feature key.

## Headset Operation (with Feature Control Switch)

**IMPORTANT NOTE:** Mitel Networks Headsets with Feature Control Switch must be installed in the dedicated headset jack (the jack nearest the front of the phone). Installation will disable your handset microphone. Disconnecting the headset at the jack or at the quick-disconnect plug restores handset operation. If handset operation is required for an extended period of time, you should press the Headset feature key to return the phone to handset mode.

*To enable Headset Operation:*

- Press the **Headset** feature key.

*To answer a call:*

- Press flashing Line Appearance key  
-OR-  
Quickly press and release the headset's feature control switch.

*To mute the headset microphone:*

- Press and hold the headset's feature control switch.

*To hang up:*

- Press **CANCEL**.  
-OR-  
Quickly press and release the headset's feature control switch.

*To disable Headset Operation:*

- Press the **Headset** feature key.

## Music

*To turn Music on and off when the phone is idle:*

1. Press **SUPERKEY**.
2. Press the **No** softkey until "Music?" appears.
3. Do one of the following:
  - To turn the music on, press the **TurnOn** softkey.
  - To turn the music off, press the **TurnOff** softkey.
4. Press **SUPERKEY**.

## Group Paging / Meet Me Answer

Group Paging allows you to page a group of phones through their built-in speakers. You can belong to as many as three paging groups with one group designated as your "prime" group.

When you need to respond to a Group Page but don't know the identity or extension number of the paging party, use the Meet Me Answer feature. You have up to 15 minutes after receiving the page to use Meet Me Answer.

### *To make a Group Page:*

1. Lift the handset.
2. Press **Direct Page** or dial **\*37**.
3. Do one of the following:
  - To page your prime page group, press **#**.
  - To page a specific page group, dial the page group directory number.
4. Speak to the dialed party after the tone.

### *To respond to a Group Page by using Meet Me Answer:*

1. Lift handset.
2. Dial **\*88**.
3. Do one of the following:
  - To respond to a page from your prime page group, press **#**.
  - To respond to a page from a specific page group, dial the page group directory number.

## Trunk Flash

The Trunk Flash feature allows you to access Centrex features (if available) while you are talking on an outside call.

### *To flash a trunk while talking on an outside call:*

1. Press **TRANS/CONF**.
2. Dial **\*57** for a single flash or **\*56** for a double flash.
3. Wait for dial tone.
4. Dial the Centrex feature access code.

## Record a Call

This feature uses your voice mail system to record your phone conversations.

**Note:** You may be required by law to inform the other party that you are recording the conversation. For specific instructions, consult your system administrator.

*To start recording while on a two-party call:*

- Press the **Record Call** key. (See *Feature Keys* elsewhere in this guide for instructions on programming a **Record Call** key to your phone.)

**Note:** Your system may be programmed to automatically begin recording external calls when you or the other answers.

*To pause recording:*

- Press the **Pause** softkey.

*To resume recording after pausing:*

- Press the **Resume** softkey.

*To stop a recording without saving it:*

- Press the **Stop&Erase** softkey.

*To stop and save a recording:*

- Press the **Stop&Save** softkey.

Putting the call on hold saves the recording; taking the call off hold starts a new recording. Depending on system programming, hanging up, or pressing **TRANS/CONF** or a **DSS** key, may also save the recording.

*To listen to a recording:*

1. Lift the handset.
2. Access your voice mailbox.
3. Follow the prompts to retrieve the recording.

## Hot Desking

Hot Desking allows you to log into the telephone system from any phone designated as a Hot Desk phone. Simply log in at the phone using your assigned Hot Desk User Extension Number and the phone immediately assumes all your speed dials, features keys, call forwarding setup, and line appearances - even your language preference for the display. Any changes you make to the phone while you are logged in--for example, adding a speed dial--are saved to your personal profile. Logging in activates your profile on any phone that supports Hot Desking.

**Note:** All Hot Desking profiles have 13 programmable keys. If you log into a phone that has a fewer number of keys, the extra ones are "hidden". Only the use of the extra keys is lost, not the features assigned to them.

*To log into a Hot Desking phone (the phone must be idle):*

1. Press the **HotDesk** softkey.
2. Press the **Login** softkey.
3. Enter your Hot Desk User Extension Number
4. Press the **OK** softkey.

*To log out of Hot Desking phone (the phone must be idle):*

1. Press the **HotDesk** softkey.
2. Press the **Logout** softkey.
3. Press the **Confirm** sofkey.

**Note:** Your profile can only be active on one phone at a time. If you log in from another phone without logging out from the first one, the system will automatically deactivate your profile on the first phone.

### Hot Desk Remote Logout

A user that has forgotten to log out of a Hot Desking phone can be logged out using any phone that supports Hot Desk Remote Logout.

*To remotely log out a Hot Desking phone:*

1. Dial **111**.
2. Dial the Hot Desk User Extension Number that you want to log out.

## Tag Call

Tag Call allows you to signal that you are the victim of a threatening or malicious call. Using the tag, your system administrator or telephone company can identify the source of the call and provide this information to appropriate personnel or authorities.

**CAUTION: Tagging a non-malicious call may result in fines or other penalties.**

*To tag a malicious call:*

- Press the **Tag Call** feature key while the call is in progress.  
See "Feature Keys" elsewhere in this guide for information on programming a Tag Call feature key to your phone.
- OR-
- Press **TRANS/CONF.**
- Dial **\*55**.

If the call was successfully tagged "Thank You" is shown on the display; otherwise, "Not Allowed" is displayed.

**Note:** Tag Call can be used on active two-party calls only. Calls on hold and conference calls cannot be tagged.







™, © Trademark of Mitel Networks Corporation.  
© Copyright 2004, Mitel Networks Corporation.  
All rights reserved.