

MITEL

5220 | IP Phone

USER GUIDE



 **MITEL** | it's about **YOU**

Contents

ABOUT YOUR PHONE	1
TIPS FOR YOUR COMFORT AND SAFETY	3
Don't cradle the handset!	3
Protect your hearing	3
Adjusting the viewing angle	4
CUSTOMIZING YOUR PHONE	5
Ringer Control	5
Handset Receiver Volume Control.....	5
Speaker Volume Control.....	5
Display Contrast Control	5
Feature Keys	6
Language Change.....	6
MAKING AND ANSWERING CALLS.....	6
Make a Call - PBX.....	7
Make an External Call - KTS	7
Make an Intercom Call - KTS	7
Answer a Call.....	7
Redial	8
Speed Call Keys	8
Speed Call - Personal.....	9
Handsfree Operation.....	10
Group Listen.....	11
Auto-Answer.....	11
CALL HANDLING.....	12
Hold	12
Hold and Page	12
Transfer	13
Conference.....	13
Conference Split.....	13
Add Held	13
Swap	14
Call Forward	15
Call Forward (Enhanced)	17
Call Forward (No Internal/External Split).....	19
Call Forward (No Internal/External Split - Enhanced)	20
Call Forward - I'm Here.....	21
Call Forward - Forced.....	21
Call Forward - Toggle.....	22
Messaging - Advisory.....	22
Messaging - Callback	23

USING ADVANCED FEATURES	23
Account Codes	23
Callback	24
Call Park	25
Call Park - System.....	26
Call Park - Specific Orbit	27
Call Pickup	27
Call Park - Destination Phone.....	28
Campon	28
Do Not Disturb.....	28
Override (Intrude).....	28
Paging - PA	29
Paging - Direct.....	30
Paging - All Set.....	31
Paging - Group	31
Direct Station Select/Busy Lamp Field (DSS/BLF)	31
DSS/BLF/Call Pickup	32
Direct Page/BLF	32
DSS/BLF/Direct Page/Call Pickup.....	32
Auto-Latch Microphone	33
Reminder	33
Reminder - Multiple	34
Handset Mute	35
Headset Operation	35
Headset Operation (Headset with Feature Control Switch)	36
Music.....	37
Park and Page.....	38
Record a Call	40
Call Logging	41
Phonebook	42
Call Monitoring.....	43
Door Opener.....	44
Night/Day Service Switch	45
Date and Time Setup	46

ABOUT YOUR PHONE

The 5220 IP Phone has ten fixed-function keys (**SUPERKEY**, **TRANS/CONF**, **REDIAL**, **MESSAGE**, **HOLD**, **CANCEL**, **SPEAKER**, **MICROPHONE**,  and ), three softkeys and 14 personal keys with built-in status indicators. The personal key on the bottom right is always your Prime Line; the remaining personal keys can be programmed as:

- Feature keys (for example, **Swap**). You can program feature keys from your phone. Your administrator can also program feature keys.
- Speed Call keys. You can program speed call keys from your phone.
- Line Appearances. Only the administrator can program line appearances.

Your telephone also features display-assisted selection of features, on-hook dialing, and a large Message Indicator.

Note: When using the **SUPERKEY**, press **Cancel** to back up one menu level.

IMPORTANT NOTE FOR HEADSET USERS:

Headsets with a feature control switch that are approved for use with the 5220 IP phone must be installed in the dedicated headset jack (the jack nearest the front of the phone). Installation will disable your handset microphone. Disconnecting the headset at the jack or at the quick-disconnect plug restores handset operation.

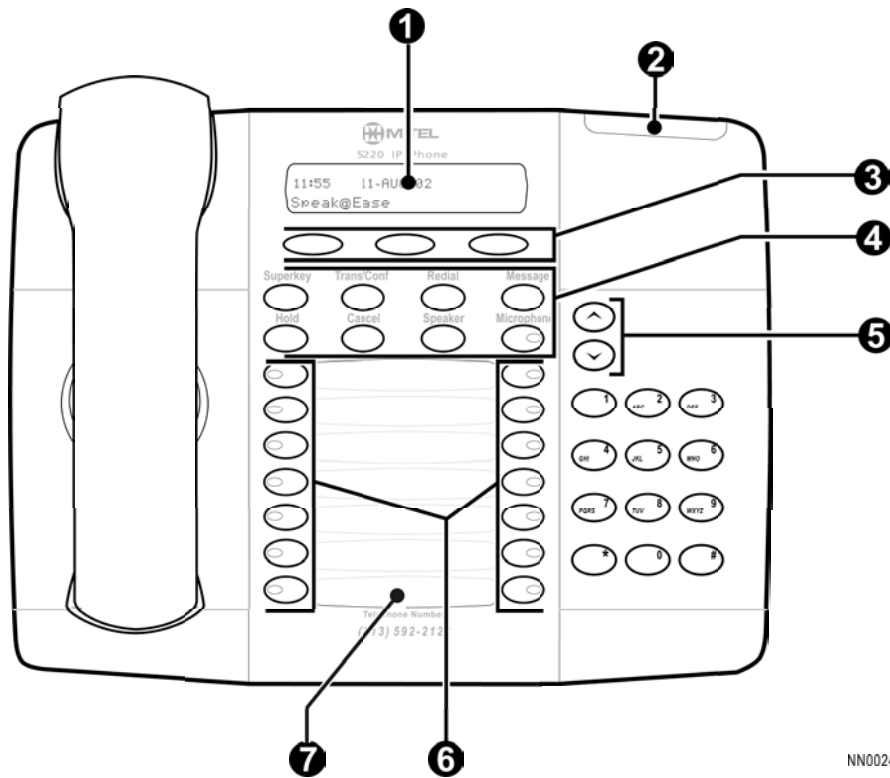

NN0024

1. Display
2. Message Waiting Indicator
3. Softkeys
4. Fixed-Function Keys
5. Volume Control
6. Programmable Feature Keys
7. Designation Card

Phone status indicators

When line is:	the indicator is:
Idle	Off
Busy	On
Ringing	Flashing slowly
On hold at your phone	Flashing rapidly
On hold at another phone	Flashing slow on/fast off

Designation Card

Write the name of the feature keys on the designation card (use the side of the card without arrows). Use the slot behind the plastic cover at the bottom of the phone to remove/insert the designation card.

TIPS FOR YOUR COMFORT AND SAFETY

Don't cradle the handset!

Prolonged use of the handset can lead to neck, shoulder, or back discomfort, especially if you cradle the handset between your ear and shoulder. If you use your phone a lot, you may find it more comfortable to use a headset. See the section on headset usage elsewhere in this guide for more information.

Protect your hearing

Your phone has a control for adjusting the volume of the handset receiver or headset. Because continuous exposure to loud sounds can contribute to hearing loss, keep the volume at a moderate level.

Adjusting the viewing angle

The stand built into your phone tilts to give you a better view of the keys and display.

To tilt your telephone for better viewing:

1. Press the release tabs on the sides of the stand.
2. Hinge the two front hooks and snap the two back hooks of the stand into either the upper or lower notches on the back of the phone.

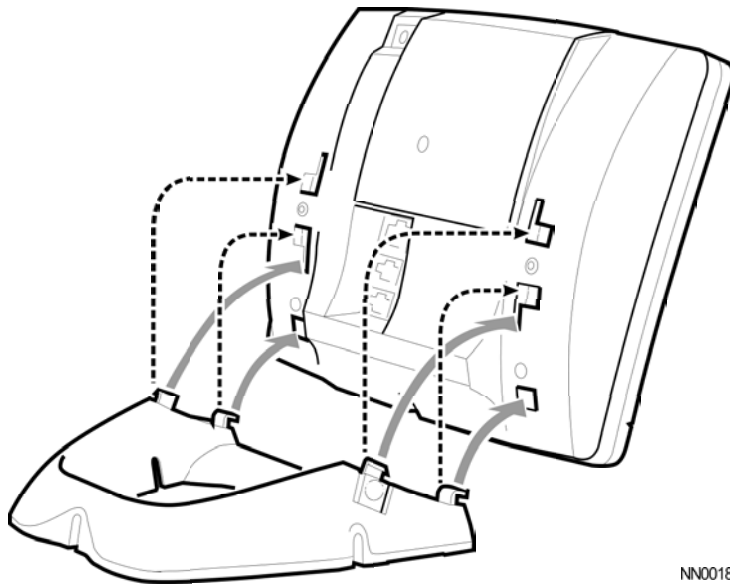

NN0018



CUSTOMIZING YOUR PHONE

Ringer Control

To adjust the Ringer Volume while the phone is ringing:

- Press  or .

To adjust the Ringer Pitch while the phone is idle:

1. Press **SUPERKEY**.
2. Press the **No** softkey until "Ringer Adjust?" appears.
3. Press the **Yes** softkey.
4. Press the **Yes** softkey.
5. Press  or  to adjust the ringer pitch.
6. Press **SUPERKEY**.

Handset Receiver Volume Control

To adjust the Handset Receiver Volume when you are using the handset:

- Press  or .

Speaker Volume Control

To adjust the Speaker Volume during a Handsfree conversation:

- Press  or .

Display Contrast Control

To adjust the Display Contrast while your phone is idle:

- Press  or .

Feature Keys

To display information about a key:

1. Press **SUPERKEY**.
2. Press a personal key.
3. Press **SUPERKEY**.

To re-program a personal key:

1. Press **SUPERKEY**.
2. Press the **No** softkey until "Personal Keys?" appears.
3. Press the **Yes** softkey.
4. Press a personal key that isn't a line key.
5. Press the **Change** softkey.
6. Press the **No** softkey until the desired feature appears.
7. Press the **Yes** softkey.
8. Press **SUPERKEY**.

Language Change

To change the display language:

1. Press **SUPERKEY**.
2. Press the **No** softkey until "Language?" appears.
3. Press the **Yes** softkey.
4. Press the **Change** softkey.
5. Press the **No** softkey until the desired language appears.
6. Press the **Yes** softkey.

MAKING AND ANSWERING CALLS

If your telephone system operates as a PBX, the Prime Line can be used for both incoming and outgoing calls. Outgoing calls require dialing a line access code (usually "9") followed by the telephone number.

In a key telephone system (KTS), the Prime Line is used for internal (Intercom) calls only. Outgoing calls require the use of Line keys.

Make a Call - PBX

1. Lift the handset.
2. Dial the extension number or a line access code (usually "9") and the telephone number for an outside call.
-OR-
Press a Speed Call key.

Make an External Call - KTS

1. Lift the handset.
2. Press a Line key.
3. Dial the telephone number.
-OR-
Press a Speed Call key.
-OR-
Press **REDIAL**.

Make an Intercom Call - KTS

An Intercom call is a call between two extensions, which either pages or rings the called extension.

To switch between a ringing intercom call to a paged intercom call:

1. Make a call.
2. Do one of the following while listening to ringback tone:
 - Press the **Direct Page** feature key.
 - Dial ***48**.

Answer a Call

- Lift the handset.
-OR-
Press the flashing Line Appearance key and lift the handset.

Note: The Auto-Latch Microphone feature described elsewhere in this guide allows you to answer and respond to internal calls handsfree.

Redial

To redial the last number that you manually dialed:

1. Lift the handset.
2. Press **REDIAL**.

Speed Call Keys

You may use Speed Call Keys to make a call or to send a string of digits, such as a password, during a call.

To dial a stored Speed Call number:

1. Lift the handset.
2. Press a **Speed Call** key.

To store a Speed Call number:

1. Press **SUPERKEY**.
2. Press the **No** softkey until "Personal Keys?" appears.
3. Press the **Yes** softkey.
4. Press a personal key that isn't a line key.
5. Press the **Change** softkey.
6. Press the **Yes** softkey.
7. Do one of the following:
 - To store a new number, enter "9" or other digit(s) used to access an outside line (if required) followed by enter the telephone number. Press **HOLD** between digits to create a one-second pause during dialing - press **HOLD** more than once to lengthen the pause).
 - To enter the last number dialed, press **REDIAL**.
8. If you want the number of be private, press the **Priv** softkey.
9. Press the **Save** softkey.
10. Press **SUPERKEY**.

Speed Call-Personal

To dial a stored personal Speed Call number:

1. Lift the handset.
2. Dial ***52**.
3. Enter an index number between **1** and **5**.

To store a personal Speed Call number:

1. Lift the handset.
2. Dial ***51**.
3. Enter an index number between **1** and **5**.
4. Enter "9" or other digit(s) used to access an outside line (if required) followed by enter the telephone number.
Press **HOLD** between digits to create a one-second pause during dialing - press **HOLD** more than once to lengthen the pause).
5. Hang up.

Handsfree Operation

To use Handsfree Operation to make calls:

1. If you want to use a Non-Prime Line, press a Line Appearance key.
2. Dial the number.
3. Communicate by using the speaker and the microphone.

To use Handsfree Operation to answer calls:

1. Press the flashing line key.
2. Communicate by using the speaker and the microphone.

To hang up while using Handsfree Operation:

- Press **SPEAKER**.

To temporarily disable the microphone during a Handsfree conversation:

- Press **MICROPHONE** (the microphone LED turns off).

To re-enable the microphone and return to the conversation:

- Press **MICROPHONE** (the microphone LED turns on).

To disable Handsfree Operation:

- Lift the handset.

To return to Handsfree Operation:

1. Press **SPEAKER**.
2. Hang up.

Group Listen

To allow others in the room to listen to the far end of a handset call:

- Press the **Group Listen** feature key.

To return to a private two-way handset call from Group Listen:

- Press the **Group Listen** feature key.

To allow others in the room to join a telephone conversation:

- Press **SPEAKER**.

To return to a private two-way handset call from Speaker:

- Press **MICROPHONE**.

Auto-Answer

To enable or disable Auto-Answer when you are using a headset:

1. Press **SUPERKEY**.
2. Press the **No** softkey until "Auto Answer?" appears.
3. Do one of the following:
 - To enable Auto-Answer, press the **TurnOn** softkey.
 - To disable Auto-Answer, press the **TurnOff** softkey.

To answer a call when you hear ringback:

- Communicate by using the speaker and the microphone.

To terminate a call:

- Press **CANCEL**.
- OR-
- Wait for the caller to hang up.

CALL HANDLING

Hold

To place a call on Hold:

- Press **HOLD**.

To retrieve a call from Hold:

1. Lift the handset.
2. Press the flashing line key.

To retrieve a call from Hold at another station:

1. Press the flashing line key.
2. -OR-
3. Dial ***23** and the number of the station that placed the call on Hold.

Hold and Page

The Hold and Page feature allows you to put a call on hold and page without having to use a feature key or code. You can also page after parking a call; see Call Park - Specific Orbit.

To place a call on hold and page:

1. Press the red **HOLD** key twice.
2. Make the page.

To place a call on hold and not page:

1. Press the red **HOLD** key.
2. Press any key except for the red **HOLD** key. The call is on hold.

Transfer

To Transfer an active call:

1. Press **TRANS/CONF**.
2. Dial the number of the third party.
3. Do one of the following:
 - To complete the Transfer, hang up.
 - To announce the Transfer, wait for an answer, consult, and hang up.
 - To cancel the Transfer, press **CANCEL**.

Conference

To form a Conference when a two-party call is already in place, or to add another party to an existing Conference:

1. Press **TRANS/CONF**.
2. Dial the number of the next party.
3. Wait for an answer.
4. Press **TRANS/CONF**.

To leave a Conference:

- Hang up.

Conference Split

To Split a Conference and speak privately with the original party:

- Press the **Split** softkey.

Add Held

To move a call on Hold to another line appearance:

1. Press the available line key.
2. Press the **Add held** softkey.
3. Press the flashing line key.

To add a call on Hold to an existing conversation or conference:

1. Press the **Addheld** softkey.
2. Press the flashing line key.

Swap

To call another party when you are in an established two-party call:

1. Press **TRANS/CONF**.
2. Dial the number.

To alternate between the two parties:

- Press the **Trade** softkey.

Call Forward

Call Forward lets you redirect incoming calls to an alternate number. "External Calls?" redirects your incoming external calls only; "Internal Calls?" redirects your incoming internal calls only. If you want to redirect both external and internal calls, you must program each separately.

"Always Forward?" redirects all incoming calls regardless of the state of your telephone. "When No Answer?" redirects calls after several rings if you don't answer. "When Set's Busy?" redirects calls when your telephone is busy. "Busy/No Answer?" redirects calls when your telephone is busy or when you don't answer.

Note: For information about "I'm Here?", see Call Forward - I'm Here.

To program Call Forward:

1. Press **SUPERKEY**.
2. Press the **No** softkey until "Call Forwarding?" appears.
3. Press the **Yes** softkey.
4. Do one of the following:
 - To program external forwarding, press the **Change** softkey.
 - To program internal forwarding, press the **No** softkey and the **Change** softkey.
5. Press the **Program** softkey.
6. Press the **No** softkey until the desired type of Call Forward appears.
7. Press the **Yes** softkey.
8. Dial the destination number.
9. Press the **Save** softkey.

To turn Call Forward on and off (once it has been programmed):

1. Press **SUPERKEY**.
2. Press the **No** softkey until "Call Forwarding?" appears.
3. Press the **Yes** softkey.
4. Do one of the following:
 - For external forwarding, press the **Change** softkey.
 - For internal forwarding, press the **No** softkey and the **Change** softkey.
5. Do one of the following:
 - To turn Call Forward on, press the **TurnOn** softkey.
 - To turn Call Forward off, press the **TurnOff** softkey.

Call Forward (Enhanced)

Call Forward lets you redirect incoming calls to an alternate number. "External Calls?" redirects your incoming external calls only; "Internal Calls?" redirects your incoming internal calls only. If you want to redirect both external and internal calls, you must program each separately.

"Always Forward?" redirects all incoming calls regardless of the state of your telephone. "When No Answer?" redirects calls after several rings if you don't answer. "When Set's Busy?" redirects calls when your telephone is busy. "Busy/No Answer?" redirects calls when your telephone is busy or when you don't answer.

Note: For information about the I'm Here? softkey, see Call Forward - I'm Here.

To program Call Forward:

1. Press **SUPERKEY**.
2. Press the **No** softkey until "Call Forwarding?" appears.
3. Press the **Yes** softkey.
4. Do one of the following:
 - To program external forwarding, press **Yes** softkey.
 - To program internal forwarding, press **No** softkey.An asterisk next to External Calls? or Internal Calls? indicates that at least one type of call forwarding is turned on.
5. Press the **Program** or **Change** softkey key to program Call Forward Always or the **Next** softkey to program another type of call forward.
6. Dial the destination number.
7. Press the **Save** softkey.

To turn Call Forward on and off (once it has been programmed):

1. Press **SUPERKEY**.
2. Press the **No** softkey until "Call Forwarding?" appears.
3. Press the **Yes** softkey.
4. Do one of the following:
 - For external forwarding, press the **Yes** softkey.
 - For internal forwarding, press the **No** softkey.
5. Do one of the following:
 - To turn Call Forward Always on or off, press the **Change** softkey, and then the **Turnoff** or **Turnon** softkey.
 - To turn another type of Call Forward on or off, press the **Next** softkey until you reach the desired display, and then press the **Change** followed by the **TurnOff** or **Turnon** softkey.
 - To turn off call forwarding and delete the destination, press the **Del** softkey.

Call Forward (No Internal/External Split)

Call Forward lets you redirect incoming calls to an alternate number. "Always Forward?" redirects all incoming calls regardless of the state of your telephone. "When No Answer?" redirects calls after several rings if you don't answer. "When Set's Busy?" redirects calls when your telephone is busy. "Busy/No Answer?" redirects calls when your telephone is busy or when you don't answer.

Note: For information about "I'm Here?", see Call Forward - I'm Here.

To program Call Forward:

1. Press **SUPERKEY**.
2. Press the **No** softkey until "Call Forwarding?" appears.
3. Press the **Yes** softkey.
4. If the **Change** softkey appears, press the **Change** softkey.
5. Press the **Program** softkey.
6. Press the **No** softkey until the type of Call Forward appears.
7. Press the **Yes** softkey.
8. Dial the destination number.
9. Press the **Save** softkey.

To turn Call Forward on and off (once it has been programmed):

1. Press **SUPERKEY**.
2. Press the **No** softkey until "Call Forwarding?" appears.
3. Press the **Yes** softkey.
4. Press the **Change** softkey.
5. Do one of the following:
 - To turn Call Forward on, press the **TurnOn** softkey.
 - To turn Call Forward off, press the **TurnOff** softkey.

Call Forward (No Internal/External Split - Enhanced)

Call Forward lets you redirect incoming calls to an alternate number. "Always Forward?" redirects all incoming calls regardless of the state of your telephone. "When No Answer?" redirects calls after several rings if you don't answer. "When Set's Busy?" redirects calls when your telephone is busy. "Busy/No Answer?" redirects calls when your telephone is busy or when you don't answer.

Note: For information about "I'm Here?", see Call Forward - I'm Here.

To program Call Forward:

1. Press **SUPERKEY**.
2. Press the **No** softkey until "Call Forwarding?" appears.
3. Press the **Yes** softkey.
4. Press the **Program** or **Change** softkey key to program Call Forward Always or the **Next** softkey to program another type of call forward. The presence of an asterisk indicates that call forwarding is turned on.
5. Dial the destination number.
6. Press the **Save** softkey.

To turn Call Forward on and off (once it has been programmed):

1. Press **SUPERKEY**.
2. Press the **No** softkey until "Call Forwarding?" appears.
3. Press the **Yes** softkey.
4. Press the **Change** softkey.
5. Do one of the following:
 - To turn Call Forward Always on or off, press the **Change** softkey, and then the **Turnoff** or **Turnon** softkey.
 - To turn another type of Call Forward on or off, press the **Next** softkey until you reach the desired display, and then press the **Change** softkey followed by the **TurnOff** or **Turnon** softkey.
 - To turn off call forwarding and delete the destination, press the **Del** softkey.

Call Forward - I'm Here

To forward calls from a remote station to your current location:

1. Press **SUPERKEY**.
2. Press the **No** softkey until "Call Forwarding?" appears.
3. Press the **Yes** softkey.
4. Press the **No** or **Next** softkey until "I'm Here" appears.
5. Press the **Yes** softkey.
6. Dial the extension of the remote station.
7. Press the **Save** softkey.

To cancel Call Forward - I'm Here from the station that set the remote forwarding:

1. Lift the handset.
2. Dial ***07**.
3. Dial the extension of the remote station.
4. Hang up.

To cancel Call Forward - I'm Here from the station that was forwarded:

1. Press **SUPERKEY**.
2. Press the **No** softkey until "Call Forwarding?" appears.
3. Press the **Yes** softkey.
4. If "External Calls?" appears, do the following:
 - a. Press the **Yes** softkey.
 - b. Press the **Del** softkey.
 - c. Press the **Next** softkey until "Internal Calls?" appears.
 - d. Press the **Yes** softkey.
 - e. Press the **Del** softkey.
5. If "External Calls?" does not appear, press the **Del** softkey.

Call Forward - Forced

To force an incoming call to be forwarded:

- Press the **Forward** softkey.

To immediately transfer to another extension's No Answer forwarding destination when making a call:

- Press the **FwdMe** feature key when it lights.

Call Forward - Toggle

This feature is useful if you want call forwarding in effect for Busy and No Answer conditions most of the time, but need to override it with Call Forward Always occasionally--for example, when you're using a second phone such as a SUPERSET 4090 cordless phone. Instead of changing the call forward programming on your main phone to turn Call Forward Always on and off, you can program a key to do it.

You can also program keys to turn Call Forward Busy, No Answer or Busy/No Answer on and off.

To toggle call forward:

- Press the programmed feature key: **Forward Always**, **Forward Busy**, **Forward No Ans**, or **Forward Busy/NA**.

For information on programming a feature key, see "Feature Keys" elsewhere in this guide.

Note: You may also program a **Forward All** key to enable and disable all call forward types that have a destination programmed.

Messaging - Advisory

To turn Messaging - Advisory on:

1. Press **SUPERKEY**.
2. Press the **No** softkey until "Advisory Msgs?" appears.
3. Press the **Yes** softkey.
4. Press the **Next** softkey until the desired message appears.
5. Press the **TurnOn** softkey.

To turn Messaging - Advisory off:

1. Press **SUPERKEY**.
2. Press the **No** softkey
3. Press the **Yes** softkey.
4. Press the **TurnOff** softkey.

Messaging - Callback

To leave a Callback Message on a telephone when you hear busy or ringback tone:

- Press **MESSAGE**.

To respond to a Message Waiting condition on your telephone:

1. Lift the handset.
2. Press **MESSAGE**.

A call is placed to the message sender (voice mail system or extension user) that left the oldest message.

To view information about the messages before responding:

1. Press **MESSAGE**.
2. Do one of the following.
 - To call the message sender, press the **Call** softkey (if available).
 - To delete the message, press the **Erase Msg** softkey.
 - To view the next message, press **MESSAGE**.

USING ADVANCED FEATURES

Account Codes

To enter an Account Code during a call:

1. Press **SUPERKEY**.
2. Press the **No** softkey until "Account Code?" appears.
3. Press the **Yes** softkey.
4. Dial the Account Code digits.
5. Press the **Save** softkey.

Callback

To request a Callback when you reach a busy or unanswered telephone:

- Press the **Callback** feature key.

To answer a Callback:

- Lift the handset.

Call Park

To park a call that is on your prime line (Line 1 key):

- Press the **Call Park** feature key.
- OR-
- Press **TRANS/CONF** and then dial ***33**.

The call is parked and you receive dial tone on your prime line.

To retrieve a parked call from your phone while your phone is idle, or while you are off-hook and hearing dial tone:

- Press the **Call Park** feature key.
- OR-
- Dial ***22**.

To retrieve a parked call while you are on a call on your prime line:

- Press the **Call Park** feature key.
- OR-
- Press **TRANS/CONF** and then dial ***22**.

You are connected to the parked call and the caller that was on your prime line is parked.

To retrieve a parked call from another phone:

1. Lift the handset.
2. Dial ***23**.
3. Dial the prime line number (extension number) of the phone that parked the call.

Note: If the phone has both a parked call and a call on hold, dialing the Remote Hold Retrieve access code will retrieve the parked call.

Call Park - System

This feature allows you to park a call from any line on your telephone not just the prime line. The number of calls you can park is limited only by the number of available system park "orbits."

To park a call in system orbit:

1. Press the lit **System Park** feature key.
2. Do either of the following:
 - Hang up
 - Press a line key to answer a call, retrieve a call or hold, or get dial tone.

To return to the caller if all the system orbits are busy:

- Press **CANCEL** to return to the caller.

To retrieve a call parked on a system orbit from any extension:

- While listening to dial tone, dial ***57** followed by the park orbit number.

Call Park - Specific Orbit

This feature allows you to park a call in a specific orbit by entering a two-digit orbit number or by pressing a feature key assigned to a specific orbit number.

To park a call in a specific orbit:

1. Press the **System Park** feature key.
2. Enter a two-digit Orbit Number (01-25).
If the selected orbit already has a parked call, press **CANCEL**, and then enter another orbit number.

To retrieve a call parked in a specific orbit:

- While listening to dial tone, dial ***57** followed by the park orbit number.

To park a call in a specific orbit using an Orbit # feature key:

- Press a free (unlit) **Orbit #** feature key. (See "Feature Key" for instructions on programming a feature key.)

Once a call is parked, you can press the same **Orbit #** to initiate a page.

To retrieve a call parked using an Orbit # feature key:

- Press the flashing **Orbit #** feature key.

Call Pickup

To answer a call that is ringing at another station in your Pickup Group:

1. Lift the handset.
2. Press the **Pickup** feature key.

To answer a call that is ringing at a station not in your Pickup Group:

1. Lift the handset.
2. Dial ***09**.
3. Dial the number of the ringing station.

Call Park - Destination Phone

Call Park - Destination Phone allows you to park an answered call on another phone. If a parked call is not retrieved after a specified length of time, a reminder occurs.

To park an active call on another phone:

1. Press **TRANS/CONF** to get dial tone.
2. Dial ***62**, and then dial the extension of the destination phone.
If the call is parked successfully, dial tone, busy tone or a page occurs. If the call is not parked, reorder tone occurs.

To retrieve a call parked on another phone:

- Do one of the following:
 - Press the flashing **Call Park** feature key.
 - Dial ***22**.

Campon

To campon to a busy station:

- Press the **Wait** softkey

To retrieve a call when you hear Campon tone:

- Press the **Trade** softkey.

Do Not Disturb

To activate and deactivate Do Not Disturb:

- Press the **Do Not Disturb** feature key. The key flashes to indicate that Do Not Disturb is active.

Override (Intrude)

To use Override when you encounter busy or DND tone:

- Press the **Intrude** feature key.

Paging - PA

To use Paging:

1. Lift the handset.
2. Do one of the following:
 - To page the default zone, press the **PA Page** feature key.
 - To page a specific zone, dial ***13** followed by the zone number (0-9).
3. Make the announcement.

Paging - Direct

To page an extension that has Whisper Announce or Off-Hook Voice Announce enabled:

1. Lift the handset.
2. Press the **Direct Page** feature key.
3. Dial the extension number.

To answer a page (indicated by a single burst of tone) when your phone is idle:

- Lift the handset.
 - OR -
- Press **MICROPHONE**.

Note: You can answer and respond handsfree to a Direct Page by using the Auto-Latch Microphone feature described elsewhere in this guide .

To answer a page while using the handset:

- Press **MICROPHONE**.
 - OR -
- If the **Respond** softkey appears, press it and hold it down as you speak.

To answer a page (indicated by a burst of tone) while on a Handsfree call:

- Press and hold down the **Respond** softkey.

To enable or disable Handsfree Answerback:

- Press **MICROPHONE** while the phone is idle.

To allow or disallow Direct Pages to your phone:

1. Press **SUPERKEY**.
 2. Press the **No** softkey until "Can Be Paged?" appears.
 3. Press the **TurnOff** softkey if you do not want to receive Direct Pages.
 - OR-
- Press the **TurnOn** softkey if you want to receive Direct Pages.

Paging - All Set

To page all telephones simultaneously through their speakers:

1. Lift the handset.
2. Press the **Direct Page** feature key.
3. Press *****.
4. Page the called party.

To answer an All Set Page:

1. Lift the handset.
2. Dial ***49**.

Paging - Group

To page all telephones in a paging group simultaneously through their speakers:

1. Lift the handset.
2. Press the **Direct Page** feature key.
3. Press **#**.
4. Page the called parties.

To respond to a Group Page:

1. Lift the handset.
2. Dial ***49**.

Direct Station Select/Busy Lamp Field (DSS/BLF)

Your phone may have keys programmed to place calls to other extensions and to show the status (idle, busy or DND) of those extensions.

To call the DSS/BLF extension:

- Press the **DSS/BLF** key.

To transfer a call to DSS/BLF extension (without Secretarial option):

1. Press the **TRANS/CONF** key.
2. Press the **DSS/BLF** key.

To transfer a call to a station (with Secretarial option):

- Press the **DSS/BLF** key.

DSS/BLF/Call Pickup

Your phone may have keys programmed to show the status (idle, busy, ringing, call on hold) of another destination and to retrieve calls ringing or on hold at the destination.

To retrieve a call ringing at the DSS/BLF destination:

- Press the slowly flashing **DSS/BLF** key.

To retrieve a call on hold at the DSS/BLF destination:

- Press the rapidly flashing **DSS/BLF** key.

Direct Page/BLF

Your phone may have keys programmed to show the busy/idle status of another extension and to page the extension.

To page a DP/BLF extension:

- Press the **DP/BLF** key.

You can page when the DP/BLF extension is idle (key dark) or busy (key steadily lit).

DSS/BLF/Direct Page/Call Pickup

Your phone may have keys that show the status (idle, busy, ringing, or call on hold) of another extension. Depending on the programming of the key, pressing it will either call the extension if it is idle, or retrieve a call ringing or on hold at the extension, or page the extension.

To pick up a call ringing at the DSS/BLF extension:

- Press the slowly flashing **DSS/BLF** key.

To retrieve a call on hold at the DSS/BLF extension:

- Press the rapidly flashing **DSS/BLF** key.

To page a DSS/BLF extension:

- Press the dark or steadily lit **DSS/BLF** key.

Auto-Latch Microphone

To set the handsfree microphone to automatically turn on or off when receiving a page or Intercom call:

1. Press **SUPERKEY**.
2. Press the **No** softkey until ""Auto Latch Mic?"" appears.
3. Press the **TurnOn** or **TurnOff** softkey.
The **MICROPHONE** key flashes to indicate that the Auto-Latch Microphone feature is in use.

Reminder

Note: The Reminder feature will not operate if Auto Answer is enabled on your phone.

To program a Reminder:

1. Press **SUPERKEY**.
2. Press the **No** softkey until "Timed Reminder?" appears.
3. Press the **Yes** softkey.
4. Enter the time in 12-hour format--for example, 01:45.
5. Press either the **AM** or **PM** softkey.
6. Press the **Save** softkey.

To view, change, and/or cancel a pending Reminder:

1. Press **SUPERKEY**.
2. Press the **No** softkey until "Timed Reminder?" appears.
3. Press the **Yes** softkey.
4. Do one of the following:
 - To change the Reminder, press the **Change** softkey, enter the new time, and press the **Save** softkey.
 - To cancel the Reminder, press the **Del** softkey.
 - To exit without canceling the Reminder, press **SUPERKEY**.

To acknowledge a Reminder when your phone rings once:

- Press the **Confirm** softkey (if available).

Reminder - Multiple

Note: The Reminder feature will not operate if Auto Answer is enabled on your phone.

To set multiple reminders (up to three):

1. Press **SUPERKEY**.
2. Press the **No** softkey until "Timed Reminder?" appears.
3. Press the **Yes** softkey.
4. Enter the time for Timer 1 in 12-hour format--for example, 01:45.
Press either the **AM** or **PM** softkey.
5. Press the **Save** softkey.
6. Press the **Yes** or **No** softkey depending on whether you want the reminder to repeat daily.
7. Repeat the first three steps, and then press the **Next** softkey to set Timer 2.
8. Repeat the procedure for Timer 3.

To view, change, and/or cancel a pending Reminder:

1. Press **SUPERKEY**.
2. Press the **No** softkey until "Timed Reminder?" appears.
3. Press the **Yes** softkey.
The reminder time for TIMER 1 appears (an asterisk beside the time indicates that the timer repeats daily, HH:MM indicates that the timer has not been programmed).
4. Press the **Next** softkey to display the other timers.
5. Do one of the following:
 - To change the time, press the **Change** softkey, enter the new time, press the **Save** softkey and then press the **Yes** or **No** softkey depending on whether you want the reminder to repeat daily.
 - To cancel the Reminder, press the **Del** softkey.
 - To exit without canceling the Reminder, press **SUPERKEY**.

To acknowledge a Reminder when your phone rings once:

- Lift the handset.
-OR-
Press the **Confirm** softkey (if available).

Handset Mute

To mute your handset's microphone during a call:

- Press the **Handset Mute** feature key.

To restore handset microphone operation:

- Press the **Handset Mute** feature key again.

Headset Operation

To use a headset with your phone, ensure that the headset is connected to the dedicated jack on the bottom of the phone.

To answer a call (when Auto Answer is disabled):

- Press the flashing line key.

To switch between headset and handset operation while in a call (see Note 2):

- You can talk using the headset when the **Handset Mute** key is lit and with the handset when the key is not lit.

To hang up:

- Press **CANCEL**.

Notes:

1. Lifting the handset on some 5220 IP phones while it is in headset mode also answers the call.
2. This feature is available on some versions of the 5220 IP phone only.
3. Disconnecting the headset while in a call, puts your phone in speakerphone mode. You can hear the other party but they cannot hear you. To talk to the other party, press **MICROPHONE**; to hang up, press **SPEAKER**.

Headset Operation (Headset with Feature Control Switch)

IMPORTANT NOTE: Headsets with a feature control switch that are approved for use with the 5220 IP phone must be installed in the dedicated headset jack (the jack nearest the front of the phone). Installation will disable your handset microphone. Disconnecting the headset at the jack or at the quick-disconnect plug restores handset operation. If handset operation is required for an extended period of time, you should press the Headset feature key to return the telephone to handset mode.

To answer a call:

- Press the flashing Line Appearance key
 - OR-
 - Quickly press and release the headset's feature control switch.
 - OR-
 - Lift the handset (see Note 1).

To mute the headset microphone:

- Press and hold the headset's feature control switch.

To hang up:

- Press **CANCEL**.
 - OR-
 - Quickly press and release the headset's feature control switch.

To switch between headset and handset operation while in a call (see Note 2):

- Press the **Handset Mute** key.

You can talk using the headset when the **Handset Mute** key is lit and with the handset when the key is not lit.

Notes:

1. Lifting the handset on some 5220 IP phones while it is in headset mode also answers the call.
2. This feature is available on some versions of the 5220 IP phone only.
3. Disconnecting the headset at the jack or at the quick-disconnect plug while in a call, puts your phone in speakerphone mode. You can hear the other party but they cannot hear you. To talk to the other party, press **MICROPHONE**; to hang up, press **SPEAKER**.

Music

To turn Music on and off when the phone is idle:

1. Press **SUPERKEY**.
2. Press the **No** softkey until "Music?" appears.
3. Do one of the following:
 - To turn the music on, press the **TurnOn** softkey.
 - To turn the music off, press the **TurnOff** softkey.
4. Press **SUPERKEY**.

Park and Page

With Park and Page, you can park a call and initiate a page all in one step. Park and Page options include

- Park and Page Set: After a call is parked, the system performs an all-set page.
- Park and Page Group: After a call is parked, the system pages your Paging Group.
- Park and Page: After a call is parked, you must enter the extension or Page Group number.
- Park and PA Page: After a call is parked, the you must enter a Paging Zone number (0-9).

See "Programming a Feature Key" for information on assigning this feature to a Personal Key.

To park a call and page a call:

1. Answer or make a call.
2. Perform one of the following:
 - To page all phones and the PA, press **Park & Page Sets**.
-OR-
Press **TRANS/CONF**, dial ***63** and dial *****.
 - To page all phones in a group and the PA, press **Park & Page Grp**.
-OR-
Press **TRANS/CONF**, dial ***63** and press **#**.
 - To page an extension number, press **Park & Page** and dial the extension.
-OR-
Press **TRANS/CONF**, dial ***63** and dial the extension.
 - To page all phones in a specified group and the PA, press **Park & Page** and dial the two-digit Page Group Number.
-OR-
Press **TRANS/CONF**, dial ***63** and dial the two-digit Page Group Number, then **#**.
 - To park a call in orbit and perform a PA Page to any or all nine Paging Zones, press **Park & PA Page** and dial the Paging Zone number (0 for all zones, 1-9 for a specific zone).
-OR-
Press **TRANS/CONF**, dial ***64** and dial the Paging Zone number (0 for all zones, 1-9 for a specific zone)

Note: To Park and Page call using speed call keys, press **TRANS/CONF** to get dial tone before pressing a speed call key programmed with the Park and Page access codes plus the digits for the required paging option (for example, an extension number to page a single phone or ***** to page all phones plus PA paging).

Record a Call

This feature uses your voice mail system to record your telephone conversations.

Note: You may be required by law to inform the other party that you are recording the conversation. For specific instructions, consult your system administrator.

To start recording while on a 2-party call:

- Press the **Record Call** feature key. (See Feature Keys elsewhere in this guide for instructions on programming a **Record Call** feature key to your phone.)

Note: Your system may be programmed to automatically begin recording external calls when you or the other answers.

To pause recording:

- Press the **Pause** softkey.

To resume recording after pausing:

- Press the **Resume** softkey.

To stop a recording without saving it:

- Press the **Erase** softkey or **CANCEL**.

To stop and save a recording:

- Press the **Save** softkey.

Putting the call on hold saves the recording; taking the call off hold starts a new recording. Depending on system programming, hanging up, or pressing **TRANS/CONF** or a **DSS** key, may also save the recording.

To listen to a recording:

1. Lift the handset.
2. Access your voice mailbox.
3. Follow the prompts to retrieve the recording.

Call Logging

Call Logging keeps track of the names (if available) and telephone numbers of all your incoming calls or only those you missed.

To program your phone to log your incoming calls:

1. Press **SUPERKEY**.
2. Press the **No** softkey until "Call Logging" appears.
3. Press **Yes**.
4. Press the **Missed** softkey to log missed calls only or the **All** softkey to log all calls.
5. Press the **Intl** softkey to log calls from other extensions only, **Extl** to log outside calls only, or **Both** to log internal and external calls.

To turn off call logging:

1. Press **SUPERKEY**.
2. Press the **No** softkey until "Call Logging" appears.
3. Press the **Yes** softkey.
4. Press the **Off** softkey.

To display the call log:

1. Press the **Callers** feature key.
2. Press the **New** softkey to display details for newly logged calls only or the **Old** softkey to display details for previously logged calls. The display shows the caller's number. Press the **Name** or **Num** softkey to display the caller's name or number.
3. If more than one call is logged, use the **Next** and **Previous** softkeys to display the others.

To return a call in the call log:

1. Display the call you want to return.
2. Do one of the following:
 - If the call is internal, press the **Call** softkey.
 - If the call is external, dial 9 and then press the **Call** softkey.
 - If the call is long distance, dial 91 and then press the **Call** softkey. You can dial up to three digits before pressing **Call**.

To delete calls from the call log:

1. Display the call you want to delete.
2. Press the **Yes** softkey to delete the displayed call only or the **All** softkey to delete all other New or Old calls.
3. Press the **Confirm** softkey to validate your request.

Phonebook

To access the Phonebook:

1. Press the **Phonebook** softkey or dial ***65**.
2. Using the keypad, enter the name or extension of the person you wish to call.

Note: Only extensions that have a voice mailbox can be dialed using Phonebook.

Call Monitoring

This feature allows you to monitor another extension user's phone conversation, either with or without the user's knowledge.

If your system is programmed to notify users that they are being monitored, they hear a beep when monitoring begins. Users that have a display telephone also see your name and extension number in the display for the duration of the call.

When monitoring a call, you can listen to the conversation but you can't speak to either party, and they can't hear you. However, you can join the conversation by forming a three-party conference

A few conditions:

- The system may be programmed to disallow monitoring of any or all extensions.
- A user can only be monitored from one extension at a time. If you try to monitor someone who is already being monitored, you receive busy tone and BUSY appears in your display.
- If the user puts the caller on hold, transfers the call, or ends the call, you are disconnected and your monitoring session ends. Note that the system can be programmed to allow monitoring to continue while the call is on hold.
- While you are monitoring, you can't make or receive calls. Anyone who calls your telephone while you are monitoring receives busy tone. The caller can leave a callback, but is unable to camp on or override your monitoring session. If you want to place an outgoing call, you must first cancel your monitoring session.

To monitor a call:

1. Lift the handset.
2. Dial ***45** followed by the number of the extension you wish to monitor.
If the user is on a call, INTRUDING followed by the user's extension number appears in your telephone display.
If the user is not on the phone, you hear busy tone and the user's extension number followed by the words IS IDLE are shown in your telephone display.
3. Press **Trans/Conf** to form a three-party conference with the user and the other party.
-OR-
Press **Exit** to end the monitoring session.

NOTE: If you wish to continue monitoring after exiting the conference, you must set up the monitor again.

Door Opener

Door Opener allows you to operate a third-party door opener. For example, when someone requires entry into a third-party building, a designated extension (or extensions) rings and on answering, the extension user can press a feature key or dial a feature access code to open the door.

To use Door Opener:

- Press **Door Opener** or press ***66**.

Night/Day Service Switching

Office telephone systems are often placed into Night Service after regular hours. Calls then ring alternate answer points--either designated extensions or a night bell. Extension users can dial the Trunk Answer From Any Station (TAFAS) code to answer calls ringing the night bell.

If permitted by system programming, you can put the system into Day service or one of two night service modes, Night1 or Night2.

To switch between Night and Day Service:

- Press the **NIGHT/DAY** feature key. (See "Feature Key" for instructions on programming a feature key.)
In Night1 service, the light in the **NIGHT/DAY** feature key flashes slowly. In Night2 service it flashes rapidly. In Day service, the light is off.

Date and Time Setup

You can change the time and date that appears on all telephones equipped with displays. The time can be displayed in either a 12- or 24-hour format, depending on system programming.

To set the time:

1. Press **SUPERKEY**.
2. Press the **More** softkey repeatedly until Time? appears on the display.
3. Enter the time in the correct format.
4. Press the **AM** or **PM** softkeys (if necessary).
5. Press the **Save** softkey.

To set the date:

1. Press **SUPERKEY**.
2. Press the **More** repeatedly until **Date?** appears on the display.
3. Press the **Yes** softkey.
4. Enter the date in the indicated format.
5. Press the **Save** softkey.

FEATURE ACCESS CODES

Tone Demonstration	27
Last Number Redial	*30
Call Hold Retrieve (Remote)	*23
Call Forwarding - Internal Only	*04
Call Forwarding - External Only	*05
Call Forwarding - All Calls	*03
Call Forwarding - I'm Here	*06
Call Forwarding - Cancel I'm Here	*07
Account Code Access	*01
Callback Busy <single digit only>	7
Callback - No Answer	*43
Call Park	*33
Dial Call Pickup	*08
Directed Call Pickup	*09
Call Park Remote	*62
Call Hold Retrieve (Local)	*22
Do Not Disturb	*10
Executive Busy Override <single digit only>	8
Paging Access To Default Zone(s)	*12
Paging Access To Specific Zones	*13
Direct Paging	*48
Automatic Wakeup/Reminder	*32
Retrieve Personal Speed Call	*52
Store Personal Speed Call	*51
Phonebook	*65
Silent Monitoring	*45
Open Door	*66



™, © Trademark of Mitel Networks Corporation.
© Copyright 2004, Mitel Networks Corporation.
All rights reserved.