

NuPoint Unified Messaging Engineering Guidelines

JUNE, 2016
RELEASE 8.2



NOTICE

The information contained in this document is believed to be accurate in all respects but is not warranted by Mitel Networks™ Corporation. The information is subjected to change without notice and should not be construed in any way as a commitment by Mitel or any of its affiliates or subsidiaries. Mitel and its affiliates and subsidiaries assume no responsibility for any errors or omissions in this document. Revisions of this document or new editions of it may be issued to incorporate changes.

No part of this document may be reproduced or transmitted in any form by any means – electronic or mechanical – for any purpose without written permission from Mitel Networks Corporation.

The trademarks, service marks, logos and graphics (collectively "Trademarks") appearing on Mitel's Internet sites or in its publications are registered and unregistered trademarks of Mitel Networks Corporation (MNC) or its subsidiaries (collectively "Mitel") or others. Use of the Trademarks is prohibited without the express consent from Mitel. Please contact our legal department at legal@mitel.com for additional information. For a list of the worldwide Mitel Networks Corporation registered trademarks, please refer to the website: <http://www.mitel.com/trademarks>.

Product names mentioned in this document may be trademarks of their respective companies and are hereby acknowledged.

Mitel® NuPoint Unified Messaging™
Engineering Guidelines
Release 8.2
Document Version 1.8

June 2016

™ Trademark of Mitel Networks Corporation
© Copyright 2016 Mitel Networks Corporation
All rights reserved

ABOUT THIS DOCUMENT	1
Overview.....	1
NUPOINT UNIFIED MESSAGING DOCUMENTATION	2
Knowing Which Document to Consult	2
General Audience.....	2
Installers	2
Administrators	2
End Users.....	3
Documents and Help Files	3
The MSL Qualified Hardware List	3
Product Release Notes	3
Knowledge Base Articles.....	4
Software Downloads	4
Related Documentation Sets.....	4
What's New in This Release	4
Release 8.2	4
Release 8.1	6
Release 8.0	8
Release 7.0 SP1	10
Release 7.0	11
SYSTEM OVERVIEW	12
Product Configurations.....	12
NuPoint UM 60	12
NuPoint UM 120	12
Virtual NuPoint UM.....	13
NuPoint on MiCollab.....	13
NuPoint Speech Auto Attendant	13
SYSTEM CAPACITIES	13
Calculating Message Storage Requirements	13
Prompt Sets	14
NuPoint UM and NP Net	14
NuPoint UM 60.....	14
NuPoint UM 120.....	15
Virtual NuPoint UM	16
NuPoint UM on MiCollab.....	17
Line Size Calculations.....	17

MINIMUM SYSTEM SPECIFICATIONS..... 17

- NuPoint UM 60 Specifications..... 17
- NuPoint UM 120 Specifications..... 18
- Virtual NuPoint UM Specifications 19
- MAPI Gateway Specifications 20
 - Physical MAPI Gateway Hardware and Software Requirements 20
 - Virtual MAPI Gateway Hardware and Software Requirements 20
 - MAPI Gateway Software Prerequisites..... 21
 - Client Throttling Policy on Microsoft Exchange 2010 SP1 21
 - Performance with Exchange 2013..... 21
- Software Requirements 21
 - Adjunct Systems 21

NETWORK ENGINEERING – IP (PBX) INTEGRATION..... 23

- Integrating NuPoint into the Network 23
- IP Bandwidth Considerations 23
- Maintaining Voice Quality on IP Networks..... 24
 - Quality of Service 24
 - IP Network Limits 25
 - Automatic Gain Control..... 26
 - Ethernet Packet Rates 26
 - Troubleshooting Voice Quality Issues 26
- NuPoint and SIP Interoperability 26

NETWORK ENGINEERING - DIGITAL AND ANALOG INTEGRATIONS..... 27

- NuPoint Standalone Digital/Analog Systems..... 27
- NuPoint Networked Digital / Analog System 27

ENGINEERING FOR OPTIMUM SYSTEM AVAILABILITY..... 27

- Power Provisioning 28
 - NuPoint Power Provisioning 28
 - Uninterruptible Power Supply (UPS) 28
- Environmental Considerations 28
- MiVoice Business Resiliency 29
- PSTN Connectivity and WAN Connectivity 29
- NuPoint Redundancy..... 29
- Geographical Considerations..... 29
- LAN Considerations..... 30
- Verifying Redundant & Resilient Operation 30

NETWORK MANAGEMENT AND SNMP	30
VMWARE INFRASTRUCTURE	30
System Performance.....	31
Supported vCenter Management Capabilities	31
Backup and Restore	33
Converting from Physical NuPoint to Virtual NuPoint UM.....	33
System Naming Restrictions	33
E-MAIL INTEGRATION	34
SMTP and Standard UM	34
Advanced UM	34
Deploying a NuPoint System with Advanced UM	35
Outlook Client Plug In (OCP)	35
SPEECH AUTO ATTENDANT	36
SAA Port Estimates	36
SAA Port Requirements	36
Speech Auto Attendant Guidelines.....	38
Line Groups for SAA	38
Phone Books and Active Directory.....	38
Integrating SAA into the Network	39
SAA Dialing Plan	39
SAA Backup and Restore.....	39
Speech Tuning and SAA Customization	40
SAA Name Recognition Problems	41
SUPPORT FOR G.711 FAX, T.38 FAX AND G.729A COMPRESSION.....	41
G.711 Fax.....	42
NuPoint Fax Printer	42
T.38 Fax and G.729a Compression - an Overview.....	43
What is T.38 and Why is it Required?.....	43
What is G.729a and Why is it Required?	43
Embedded G.729a Support.....	44
Using a 3300 ICP Gateway to Support T.38 and/or G.729a	45
T.38 & G.729a Configuration Details	45
T.38 Call Routing – Fax Originating on a User Gateway	47
T.38 Call Routing – Fax Originating on the PSTN	47
G.729a Call Routing to NuPoint	48

UPGRADES AND MIGRATION 49

 Physical NuPoint..... 49

 Upgrading Virtual NuPoint UM..... 49

APPENDIX A – NUPOINT PORTS 50

APPENDIX B – NUPOINT-MIB MODULE DESCRIPTION 52

 TRAPSSMI.SMI 52

 OBJID.SMI..... 57

 TYPES.SMI 59

LIST OF TABLES

Table 1. Prompt Sets	14
Table 2. System Capacities for NuPoint UM 60	14
Table 3. System Capacities for NuPoint UM 120	15
Table 4. System Capacities for Virtual NuPoint UM	16
Table 5. Minimum System Requirements: NuPoint UM 60	18
Table 6. Virtual NuPoint UM Deployment Configurations	19
Table 7. Physical MAPI Gateway Requirements and Capacity (Single Core)	20
Table 8. Virtualized MAPI Gateway Requirements and Capacity	20
Table 9. Minimum Software Requirements	22
Table 10. Port Characteristics	23
Table 11. Quality of Service L3 DSCP Values	25
Table 12. Voice over IP: Network Limits	25
Table 13. Fax over G.711 (Pass Through): Network Limits	26
Table 14. Virtual NuPoint UM Backup & Restore Methods	33
Table 15. NuPoint Advanced UM Requirements/Compatibility	35
Table 16. SAA Port Allocation Worksheet	38
Table 17. NuPoint Fax Printer Supported OS Versions	43
Table 18. NuPoint Ports Descriptions.....	50

List of Figures

Figure 1. NuPoint UM Deployment	23
Figure 2. SAA Deployment	39
Figure 3. MxIII 192 G/W	46
Figure 4. Fax Call, User G/W to NuPoint	47
Figure 5. Fax Call, PSTN to NuPoint.....	48
Figure 6. G.729a Call to NuPoint.....	49

ABOUT THIS DOCUMENT

OVERVIEW

This document provides guidelines for implementing a Mitel® NuPoint Unified Messaging™ (NuPoint) solution. It includes information about network requirements, deployment recommendations, PBX requirements, and server requirements.

This document also provides guidelines for Virtual NuPoint UM.

For more information about product features and functionality, refer to the *NuPoint Unified Messaging System Administration Help, Release 7.0*, and the *NuPoint Unified Messaging General Information Guide, Release 7.0*, available at Mitel OnLine.

NUPOINT UNIFIED MESSAGING DOCUMENTATION

At Mitel OnLine (www.mitel.com) you can access product documentation, Knowledge Base articles, Release Notes, and the Mitel Standard Linux (MSL) Qualified Hardware List. You must be a registered user to access Mitel OnLine.

KNOWING WHICH DOCUMENT TO CONSULT

The NuPoint Unified Messaging (NuPoint) documentation set includes the following components:

General Audience

General Information Guide: includes general information on systems architecture, resiliency, feature descriptions, licensing, and geographic availability and provides an overview of administration and maintenance.

Installers

Release Notes: includes information on software release history, supported upgrade configurations, new feature specifics, known issues, and customer found issues resolved in this particular software release.

Technician's Handbook: includes information on hardware and software requirements, platforms and configurations, as well as detailed procedures for installations, basic maintenance, upgrades, data migration, configuring MSL, and troubleshooting systems and features.

Engineering Guidelines (this guide): Includes information on system capacities, system requirements, and network engineering. This information should be considered prior to installation of the NuPoint system.

Optional Integrations Guide: includes explanations and examples for the Enhanced Simple Message Desk Interface (ESMDI), Enhanced in Band Integration (EIB), T1/E1 Simple Message Desk Interface, and Enhanced Data Link Integration (EDLI).

3300 IP Communications Platform Engineering Guidelines: information required to engineer a MiVoice Business system for a customer site. The guidelines are intended to highlight specific areas of the product that need to be considered before installation

3300 Resiliency Guidelines: a comprehensive overview of the Mitel Resiliency solution and offer customers the tools to understand, plan, and implement a resilient network.

Administrators

System Administration Help (with Call Director for System Administrators): includes information on post-installation instructions, system administration and maintenance, configuring and managing NuPoint UM and optional features, and troubleshooting Advanced UM using Web Console and Text Console.

Web Console Online Help: the same content as the System Administration Help file but does not include Text Console procedures.

End Users

Web View Help: includes information on the features that are available to users through the web client interface. It includes configuration information and describes unified messaging features.

Messaging User Guide: includes information on setting up and using voice mailboxes, managing voice and email messages, using PCs to receive and manage messages, and the record-a-call, fax, and speech auto attendant features.

Call Director Web Help: includes information on configuring automated attendant call flows to handle calls when you can't answer them personally.

Mitel TUI Quick Reference Guide: This one-page document explains how to access voice mailboxes and identifies telephone user interface (TUI) main menu options.

Speech Navigation in North American English – End User Guidelines: This one-page document provides recommendations to end users to make best use of the speech navigation feature. It should be provided to end users when they are enabled for the speech navigation feature. Accessing Documentation, Release Notes, Articles, and Downloads

The following sections detail how to access information on NuPoint UM.

Documents and Help Files

1. Log in to Mitel OnLine.
2. Point to Support and then click Product Documentation.
3. In the right pane, select Product Documentation.
4. Point to Messaging and click NuPoint Unified Messaging.
5. A list of documents intended for System Administrators is displayed. Select a document from the list or select Show End User Documents or Show Archived Documents to access end user or archived documents.

The MSL Qualified Hardware List

1. Log in to Mitel OnLine.
2. Point to Support and then click Product Documentation.
3. Click the Product Documentation link.
4. To search for a document, press CTL + F.
5. To access the Mitel Standard Linux Qualified Hardware list, type Mitel Standard Linux in the CTL + F search box.

Product Release Notes

1. Log in to Mitel OnLine.
2. Point to Technical and then click Knowledge Base.
3. In the left pane, click Knowledge Base.
4. In the Product list, select Mitel NuPoint UM IP (Standard).
5. Under Article Type, select Release Notes and click Search.

Knowledge Base Articles

1. Log in to Mitel OnLine.
2. Point to Technical and then click Knowledge Base. In the left pane, click Knowledge Base.
3. In the Product list, select the appropriate NuPoint product.
4. Under Article Type, select the type of article to be viewed.
5. Specify other search parameters to narrow your search and click Search.

Software Downloads

1. Log in to Mitel OnLine.
2. Point to Support and then click Software Downloads.
3. Select the appropriate Mitel NuPoint UM link.
4. Click the download link for your selected release and follow the instructions on the software download page.

RELATED DOCUMENTATION SETS

The Mitel E-docs site also provides references for these related Mitel products:

Mitel Standard Linux (MSL):

- MSL Qualified Hardware List
- Installation and Administration Guide:
- General Information Guide
- Readme First
- Engineering Guidelines
- Installation and Maintenance Guide
- Administrator Portal Help
- End User Portal Help
- Mitel Integrated Configuration Wizard Help

WHAT'S NEW IN THIS RELEASE

This section lists the features and enhancements included in the each software release.

Release 8.2

Table 1. Technology Alignment with Release 8.2

PRODUCT	VERSION SUPPORTED
Call Control Servers	
MiVoice Business	6.0 SP3 (12.0.3.24), 7.0, 7.1 and 7.2

MiVoice MX-ONE	6.1 SP1
Browsers (operable with Web Console and Web View interfaces)	
Microsoft Edge	21
Internet Explorer	9, 10, 11
Apple Safari	9 and higher
Google Chrome	46 and higher
Mozilla Firefox	41 and higher
Operating Systems (operable with Web Console and Web View interfaces, OCP and Fax Printer application)	
Microsoft Windows	7.0, 8.0, 8.1 and 10
Apple OS X (supports Web View only)	10.9.x
MAPI Gateway servers	
MS Windows	8 Professional (64-bit) 10 (64-bit) Server 2008 R2 (64-bit) Server 2012 R2 (64-bit)
Email Servers for Advanced UM	
Microsoft Exchange	2010 SP3, 2013 CU11 and 2016 (Exchange 2016 supports IMAP but not MAPI)
Google Mail (Gmail)	N/A (web-based)
Office 365	N/A (web-based)
Active Directory Snap-in application and server	
MS Active Directory Services (data source)	2008 R2 and 2012 R2
MS Exchange Server	2010, 2013 with CAS
Presence application and server	
MS Active Directory Service (data source)	2008
MS Live Communication Server (LCS)	2005 SP2
MS Office Communications Server (OCS)	2007
Email Clients for Advanced UM	
Microsoft Outlook	2010, 2013 SP1 and 2016

Virtualization platforms	
VMware vSphere	For details concerning the currently supported software application versions, see the Virtual Appliance Deployment Solutions Guide available at Mitel Online.
Microsoft Hyper-V	

- **Advanced UM Enhancements:**
 - The IMAP mail server adapter is supported on Microsoft Exchange 2016.
 - The Outlook Client Plug-in (OCP) is supported on Microsoft Outlook 2016 (32- and 64-bit).

For details regarding feature requirements, see the NuPoint UM General Information Guide.

- **Support for Additional Languages:** The following new languages are now supported: Danish, European Spanish, Italian, and European Portuguese.
- **Virtualization:** For details concerning VMware vSphere and Microsoft Hyper-V version support, software and hardware requirements, supported features and configurations, and installation and upgrade instructions, refer to the *Mitel Virtual Appliance Deployment Guide* on Mitel Online.

Release 8.1

Table 2. Technology Alignment with Release 8.1

PRODUCT	VERSION SUPPORTED
Call Control Servers	
MiVoice Business	6.0 SP3 (12.0.3.24), 7.0, 7.1 and 7.2
MiVoice MX-ONE	6.0 SP2
Browsers (operable with Web Console and Web View interfaces)	
Microsoft Edge	21
Internet Explorer	9, 10, 11
Apple Safari	9 and higher
Google Chrome	46 and higher
Mozilla Firefox	41 and higher
Operating Systems (operable with Web Console and Web View interfaces, OCP and Fax Printer application)	
Microsoft Windows	7.0, 8.0, 8.1 and 10
Apple OS X (supports Web View only)	10.9.x
MAPI Gateway servers	

MS Windows	8 Professional (64-bit) 10 (64-bit) Server 2008 R2 (64-bit) Server 2012 R2 (64-bit)
Email Servers for Advanced UM	
Microsoft Exchange	2010 SP3 and 2013 CU11
Google Mail (Gmail)	N/A (web-based)
Office 365	N/A (web-based)
Active Directory Snap-in application and server	
MS Active Directory Services (data source)	2008 R2 and 2012 R2
MS Exchange Server	2010, 2013 with CAS
Presence application and server	
MS Active Directory Service (data source)	2008
MS Live Communication Server (LCS)	2005 SP2
MS Office Communications Server (OCS)	2007
Email Clients for Advanced UM	
Microsoft Outlook	2010 and 2013 SP1
Virtualization platforms	
VMware vSphere	For details concerning the currently supported software application versions, see the Virtual Appliance Deployment Solutions Guide available at Mitel Online.
Microsoft Hyper-V	

- **Call Director enhancement:** When users add a Caller ID Filter to a call flow, they can program up to twenty numbers to be filtered.
- **Virtualization Features:**
 - After you upgrade NuPoint UM software on a VMware platform, the system will automatically restore the database and licensed software blades. Previously, these steps had to be performed manually.
 - For details concerning VMware vSphere and Microsoft Hyper-V version support, software and hardware requirements, supported features and configurations, and installation and upgrade instructions, refer to the Mitel Virtual Appliance Deployment Guide on Mitel Online.



Note: By default, Windows 10 uses white window title bars, which may be difficult to read in some NuPoint applications. To specify a new color for your title bars, access **Settings > Personalization > Colors**, select a color other than white, and click the **Show color on Start, taskbar, action center, and title bar** option. For

more information, search the web for the following topic: "How to Get Colored Window Title Bars on Windows 10."

Release 8.0

Table 3. Technology Alignment with Release 8.0

PRODUCT	VERSION SUPPORTED
Call Control Servers	
MiVoice Business	6.0 SP3, 7.0, 7.1
MiVoice MX-ONE	6.1 SP2
Browsers (operable with Web Console and Web View interfaces)	
Internet Explorer	9, 10, 11
Apple Safari	7.0, 7.1
Google Chrome	40, 41 and 42
Mozilla Firefox	37, 38 and 39
Operating Systems (operable with Web Console and Web View interfaces, OCP and Fax Printer application)	
Microsoft Windows	7.0, 8.0, 8.1
Apple OS X (supports Web View only)	10.9.x
Server functioning as a Gateway, Active Directory, or Database Backup repository	
Microsoft Windows Server (with Active Directory Snap-in for SAA)	Windows 2008, 2012 (32 and 64 bit)
Email Servers for Advanced UM	
Microsoft Exchange	2010, 2013 CU8 with CAS
Lotus Domino	7
Google Mail (Gmail)	N/A
Office 365	N/A
Email Clients for Advanced UM	
Microsoft Outlook	2010, 2013 SP1
Lotus Notes	7

- **Technology Retirement** — Effective R8.0, NuPoint UM no longer supports the following:
 - Operating systems: Windows XP.
 - Email servers: Exchange 2000; Exchange 2003; Exchange 2007.

- Email clients: Outlook 2000; Outlook 2003; Outlook 2007.
- Features/Applications: NP Receptionist; Ops Manager.
- **Dial-by-Name (DBN) Enhancements:**
 - Callers can now be prompted to dial either a first or last name to reach a mailbox owner. Previously, callers were prompted to simply dial "a name" which could be either a first name or a last name, depending on how the mailbox was originally programmed. Dial-by-Name can be programmed as feature of the NuPoint Voice Application or as a call flow action in Call Director.
 - In all supported languages, the prompts have been updated to say "Press 7 for the letters P, Q, R and S" and "Press 9 for the letters W, X, Y and Z".
- **12/24 Hour Clock:** Mailbox owners can now view message timestamps in the clock format they are familiar with, based on their language. This means that users who speak English or Latin American Spanish will receive message time stamps in 12-hour format (for example, 9:00 a.m. or 3:00 p.m.) while users who speak any other language will receive message time stamps in 24-hour format (for example, 9:00 hour or 15:00 hour). By selecting a language when they log in to Web View, mailbox owners receive message time stamps in the format for that language. Similarly, when mailbox owners log in through the TUI, they receive time stamps in the format that matches the LCOS language setting assigned to their mailbox.
- **Additional Languages:**
 - NuPoint UM now supports the installation of up to 25 prompt languages. Prior to R8.0, only nine prompt languages could be installed (English plus eight others).
 - Support has been added for three additional Nordic languages: Finnish, Swedish and Norwegian. Callers can receive prompts in these languages, and users can select one of them when accessing the Web View interface. The new languages are not available, however, in the Call Director interface.
 - Special accents and characters are permitted for mailbox names, such as the name "Jörgen Björkner." Note that when callers search for such a name using the dial by name feature, they must use equivalents for the accented characters (press 6/O on their telephone dialpad in order to select the letter ö).
 - The Bilingual Service feature has been expanded to five languages, making it "Multilingual." Activate the feature by installing the alternate-language prompt software on NuPoint, configuring a line group with up to five Language Prompts, and then (optionally) adding the Language Router action to a Call Director call flow. When callers reach the Message Center or Receptionist application, they will hear an initial greeting asking them to select one of the languages. Thereafter, they will receive prompts in their selected language.
 - All static text in emails sent to end users regarding voice and fax messages is consistent with the language associated with the user's account.
- **Faxes in PDF or TIFF format:** Depending on the system configuration, you can receive faxes in either PDF or TIFF format. Previously, faxes could only be received in TIFF format.
- **New Call Director template:** A new system template has been created, called NP Receptionist, which provides the functionality of a simple automated attendant. The template greets the caller, asks for an extension number, and transfers the call to the destination. The existing NP Receptionist optional feature is still available; however, its use is not recommended.
- **Unified Messaging Improvements:**

- Email notification when mailbox is full: Mailbox owners will receive an email message when their voice mailbox is approaching its capacity (80% full). The email is sent on a daily basis until the message count is reduced, and includes a link to Web View to facilitate message management. This feature supplements the existing functionality where users receive a verbal alert through the TUI. See LCOS Parameters and Defaults and Feature Bit 146.
- Display caller name in emails: When the name of the caller is available, it will be displayed in the email header rather than the calling number identification (CLI). The calling number will continue to appear in the body of the message to facilitate easy callback from mobile devices.
- **Virtualization Features:**
 - VMware Support: vNuPoint UM Release 8.0 supports the latest VMware hypervisor software, including vSphere 5.0, 5.1 and 5.5.
 - Microsoft Hyper-V Support: vNuPoint UM Release 8.0 supports Windows Server Virtualization (Hyper-V), the Windows native hypervisor.

For software and hardware requirements, supported features and configurations, and installation and upgrade instructions, refer to the *Mitel Virtual Appliance Deployment Guide* on Mitel Online.

- **Integration with SIP-based New Call Control products:** Currently, NuPoint UM in MiCollab supports standard voicemail features when integrated with MiVoice Office 250 over SIP. With Release 8.0, NuPoint UM will support a similar feature set with the MiVoice MX-ONE (for MiCollab and Standalone) and MiVoice 5000 (for MiCollab only). Note that when you add the MX-ONE as Network Element on a Standalone NuPoint UM system, you may now enable support for up to 240 SIP ports.
- **System Improvements (with Mitel Standard Linux R10.3):**
 - NuPoint Release 8.0 is supported as a 32-bit application on the 64-bit distribution of MSL Release 10.3.
 - To install NuPoint Release 8.0, you must do a complete system backup and then perform a fresh install of the MSL operating system, following by a database restore. You may use a database from NuPoint Release 5.0 SP1 or later. See the NuPoint UM Technician's Handbook for instructions.

Release 7.0 SP1

Technology Alignment for NuPoint UM Release 7.0 SP1

- Browser Support: The Web Console and Web View interfaces have been tested and verified with Internet Explorer 11.0.11, Mozilla Firefox versions 3.5 to 31.0, Google Chrome 36.0, and Safari 7.0.6.
- Operating System Support: The Web Console and Web View interfaces and the OCP and Fax Printer applications have been tested and verified with Windows Vista, 7, 8 and 8.1. The Web View interface has been tested and verified with Apple OS X version 10.9.

General Improvements

- The Advanced UM Configuration screen now includes a Restart button in addition to the Save, Reset and Cancel buttons. The new button can be used to restart Advanced UM while all other NuPoint services remain running.
- FCOS 14, which is assigned to NuPoint mailboxes that are created in the MiCollab platform, now includes feature bit 081 by default. This feature bit prompts a user to enter

a correct passcode only once after having entered an incorrect passcode. Without feature bit 081, the correct passcode must be entered twice.

Advanced UM Enhancements

- The mail server adapters (IMAP and MAPI) are supported on Microsoft Exchange 2013 SP1.
- NuPoint UM now supports up to 2500 Advanced UM users with a Gmail (Google Apps) hosted email configuration.

Release 7.0

New Features

- Advanced UM integration with Gmail using OAuth2.0: Google is stopping support for OAuth1.0 imminently and is advising users to move to OAuth2.0. In Release 7.0, NuPoint UM adds support for OAuth2.0.
- Advanced UM integration with Microsoft 365: Release 7.0 adds Advanced UM integration with Microsoft 365. Up to 500 users are supported.
- Import/Export of distribution lists: Now an administrator can import and export distribution lists of a mailbox. Large distribution lists are managed more efficiently using this method.
- Call Director improvements: The Call Director is a complex tool. To help the user master the tool, the following improvements have been made:
 - Context sensitive help
 - Print the entire call flow; top level only
 - Schedule action nodes now work with time zones

Virtualization Features

- Microsoft Hyper-V qualification: Release 7.0 qualifies NuPoint UM with Microsoft Hyper-V. A procedure and a guideline are provided to install NuPoint on a Hyper-V virtual machine.
- VMWare vSphere 5.5: Release 7.0 adds vSphere 5.5 to the list of supported VMWare vSphere versions.
- vNPM to support 240 ports: To offer an upgrade path to our M640 customers, release 7.0 offers the Large Enterprise edition of vNPM that supports 240 ports; the same number of ports as an Active/Passive M640.

SYSTEM OVERVIEW

NuPoint Unified Messaging (NP-UM) is a powerful, server-based voice processing system that provides users with the ability to access and manage their messages: email, voice or fax, from a single interface using an email client such as Outlook, Notes or NuPoint Web View.

The NP-UM application is also available as an application within the Mitel MiCollab. When included in MiCollab, almost all the functionality of the standalone NP-UM, as described in this guide, is supported. **There are notable differences, however, and these are summarized in an Appendix of the NuPoint General Information Guide.**

Engineering Guidelines for NP-UM on MiCollab are covered in the MiCollab Engineering Guidelines.

NP-UM can be integrated directly with either the Mitel MiVoice Business or the MiVoice Office 250 products. It can also be integrated with 3rd-party PBXs through media gateways. NP-UM can be deployed in a mixed vendor network and remain in service during a phased migration to a Mitel PBX.

The following capabilities are supported by NP-UM systems:

- Extensive Voice Messaging
- Basic Unified Messaging
- Call Director

Optional features are also available, such as

- Speech Navigation
- Additional Unified Messaging
- Fax services
- Speech Recognition Auto Attendant
- Hospitality Features.

PRODUCT CONFIGURATIONS

There are several NuPoint product versions described in this document; the versions are:

NuPoint UM 60

NuPoint UM 60 is a software only solution that runs on any server in the "Entry Level" or "Mid-range Level" category listed in the Mitel Standard Linux Qualified Hardware List, available at Mitel OnLine. The server is purchased separately so that the customer can select a hardware platform and warranty that meets their needs. NuPoint UM 60 can support up to 60 ports.

NuPoint UM 120

NuPoint UM 120 is identical to NuPoint UM 60 with the exception that it can support up to 120 ports.

Virtual NuPoint UM

Virtual NuPoint UM supports all features of NuPoint UM with one exception: Use as a standalone Speech Auto Attendant (SAA) is not supported.

Virtual NuPoint UM runs as a VMware virtual appliance (vApp) on VMware Hypervisor (ESXi). Virtual NuPoint UM 7.0 provides the following new functionality:

- Three resource profiles: 60, 120 or 240 ports for flexible deployment
- Support for VMware vSphere 5.5

Starting in release 7.0, NuPoint UM supports the Microsoft Hyper-V platform for 60 and 120 port implementations. One installs NuPoint on a Hyper-V virtual machine as if it was a standard hardware platform.

For more information concerning support for VMware features, see the Mitel Virtual Appliance Deployment Solutions Guide.

NuPoint on MiCollab

NuPoint is also available as one of the applications in the combined application offering provided by the MiCollab product. As part of MiCollab, NuPoint Unified Messaging is licensed on a per-mailbox basis. For more information about MiCollab, see the MiCollab documentation available at Mitel OnLine.

NuPoint Speech Auto Attendant

NuPoint Speech Auto Attendant (SAA) is an application that will dial a telephone extension based on a spoken name, spoken digits or DTMF digits dialed. SAA can be deployed as a standalone utility or as part of the NP_UM application.

SYSTEM CAPACITIES

The following section provides the system capacities for the various NuPoint editions and guidelines to help determine how much message storage capacity is required.

Licensing options may impose further restrictions on a particular system; the following information assumes that license maximums are in place.

CALCULATING MESSAGE STORAGE REQUIREMENTS

It is important to understand the message storage requirements of your environment. The following factors affect the calculation:

- Maximum number of messages allotted per user
- Maximum message length
- Days to keep read messages
- Days to keep unread messages

Messages are stored in ITU G.711 format and occupy approximately 28.8 MB of disk space per hour of recording.

You can use the following formula to calculate the storage required per mailbox:

$$A \times 8000 \text{ bytes per second} \times N$$

Where:

A = Average Message Length (In seconds)

N = Number of messages per mailbox

If you have an average voice mail message length of 30 seconds and a maximum of 200 messages per mailbox, the storage required is:

$$30 \times 8000 \text{ bps} \times 200 = 48 \text{ MB per mailbox}$$

PROMPT SETS

North American English (mnemonic and numeric overlay) prompts are included in the base pack and cannot be removed. Two additional languages of the customer's choice are included in the base pack.

NA English (mnemonic and numeric overlay) and 7 additional prompt sets can be installed on a single system for a maximum of 8 prompt sets. Customers may select NA English Numeric Full set, or some other languages entirely (eg. Spanish numeric) as the other two "included" prompt sets.

If more languages are required, the customer may purchase and install up to 5 additional prompt sets.

Overlay prompt sets do not count towards the maximum.

Table 4. Prompt Sets

PROMPT SET NAME	EXAMPLE	LANGUAGES	LICENSING
Mnemonic	Press P to play	NA English only	Included in the Base Pack. Cannot be removed.
Numeric Overlay	Press 7 to play.	NA English only	Included in Base Pack. If applied, all users will hear "Press 7 to play".
Numeric Full Set	Press 7 to play	NA English and many languages	Not included in Base Pack. If applied, both Mnemonic and Numeric can be used. Users will hear "Press P to Play" or "Press 8 to play", depending on the LCOS.

NUPOINT UM AND NP NET

NP Net is an optional networking feature for NuPoint Unified Messaging servers that allows you to connect NuPoint UM systems together. If connected with NP Net the NuPoint supports up to 7 calls/port/hour.

NUPOINT UM 60

Table 5. System Capacities for NuPoint UM 60

SYSTEM FEATURE	MAXIMUM CAPACITY
Voice Mailboxes	57,000

Voice Channels/Ports	60 ports – Digital/Analog Line Integration via DMGs 60 ports – IP via 3300 60 ports – T1 QSIG/PRI via two 3300 Gateways 60 ports – T1D4 via two 3300 Gateways 60 ports – E1 via 2 3300 Gateways Note: A mixed integration is supported, meaning that there can be any combination of the above; however the number of total ports cannot exceed a maximum of 60.
Storage Hours	The recording storage capacity for NuPoint UM 60 is 8000 hours or greater depending on the storage capacity of the MSL qualified server. See note, below.
Web View sessions	50 concurrent sessions
Advanced UM Users	500 users – IMAP with Exchange 2010 SP3, 2013 SP1 and 2016 500 users – IMAP with Office 365 2500 users – MAPI gateway(s) with Exchange 2010 SP3 and 2013 SP1 2500 users – IMAP with Gmail (Google Apps)
MAPI Gateway	Up to 6
Advanced UM with TTS	12 ports
G.729a	No impact: same performance as G.711



Note: To support 8000 hours of recording, the minimum hard drive size for the server should be around 350GB. The hard drive must store not only 8000 hours of recording at 8000KBps but also the OS, the software and system prompts for each language installed. Finally, overhead disk space is needed to perform backup/restore.

NUPOINT UM 120

Table 6. System Capacities for NuPoint UM 120

SYSTEM FEATURE	MAXIMUM CAPACITY
Voice Mailboxes	120,000
Voice Channels/Ports	120 ports – Digital/Analog Line Integration via DMGs 120 ports – IP via 3300 92 ports – T1 QSIG/PRI via two 3300 Gateways 96 ports – T1D4 via two 3300 Gateways 120 ports – E1 via 2 3300 Gateways Note: A mixed integration is supported, meaning that there can be any combination of the above; however, the number of total ports cannot exceed a maximum of 120.
Storage Hours	15,000 or more hours (depending on server specifications)

Web View sessions	60 concurrent sessions
Advanced UM Users	500 users – IMAP with Exchange 2010 SP3, 2013 SP1 and 2016 500 users – IMAP with Office 365 2500 users – MAPI gateway(s) with Exchange 2010 SP3 and 2013 SP1 2500 users – IMAP with Gmail (Google Apps)
MAPI Gateway	up to 6
Advanced UM with TTS	24 ports
G.729a	No impact: same performance as G.711



Note: To support 15000 hours of recording, the minimum hard drive size for the server should be around 650GB. The hard drive must store not only 15000 hours of recording at 8000KBps but also the OS, the software and system prompts for each language installed. Finally, overhead disk space is needed to perform backup/restore.

VIRTUAL NUPOINT UM

Table 7. System Capacities for Virtual NuPoint UM

SYSTEM FEATURE	MAXIMUM CAPACITY		
	Virtual NuPoint UM 60 Port Profile (Small Business)	Virtual NuPoint UM 120 Port Profile (Enterprise)	Virtual NuPoint UM 240 Port Profile (Large Enterprise)
Voice Mailboxes	Up to 57,000*	Up to 120,000*	Up to 120,000*
Voice Channels/Ports	60 ports	120 ports	240 ports**
Storage Hours	Up to 2,500 hours	Up to 5,000 hours	Up to 5,000 hours
Web View sessions	60 concurrent sessions	60 concurrent sessions	60 concurrent sessions
Advanced UM Users	500 users – IMAP with Exchange 2010 SP3/2016 2500 users – MAPI gateway(s) with Exchange 2010 SP3/2013 SP1 2500 users – IMAP with Gmail (Google Apps)	500 users – IMAP with Exchange 2010 SP3/2016 2500 users – MAPI gateway(s) with Exchange 2010 SP3/2013 SP1 2500 users – IMAP with Gmail (Google Apps)	500 users – IMAP with Exchange 2010 SP3/2016 2500 users – MAPI gateway(s) with Exchange 2010 SP3/2013 SP1 2500 users – IMAP with Gmail (Google Apps)
MAPI Gateway	Up to 6		
Advanced UM with TTS	12 ports	24 ports	24 ports
G.729a	When G.729 is used, approximately 25% fewer ports are supported.	When G.729 is used, approximately 25% fewer ports are supported.	When G.729 is used, approximately 25% fewer ports are supported.

***Note:** While the maximum number of mailboxes available in Virtual NuPoint UM is the same as that of the

physical versions, the amount of storage is more limited. Unlike physical NuPoint servers, virtual storage cannot be extended with the purchase of larger storage drives. The maximum number of mailboxes is dependent upon the storage requirements of mailbox owners. Please refer to “Calculating Message Storage Requirements” in this document.

****Note:** Only the 60 and 120 port versions of vNuPoint UM can be implemented on Microsoft Hyper-V. The 240 port version is unsupported.

For Example:

NuPoint UM stores audio at 8 KB per second. Assuming that every mailbox has the maximum of 200 messages, and messages average 30 seconds in length, then each mailbox requires 1.66 hours of storage $[(30 \times 200) / 60] / 60$. In this scenario, Virtual NuPoint UM's 2500 hours of storage would provide for 1500 mailboxes. If each mailbox stored only 50 average messages (requiring only .415 hours of storage), then mailbox capacity is 6000.

For more detailed information on determining message storage requirements, see “Message Storage Capacity” in this document.

NUPOINT UM ON MICOLLAB

System capacities for NuPoint on MiCollab are described in the MiCollab Engineering Guidelines, which can be found on Mitel OnLine.

LINE SIZE CALCULATIONS

Line size refers to the number of voice mail ports or lines a NuPoint system needs. Often the answer depends on the application. If the NuPoint system is used as the Auto Attendant of an organization to answer all incoming calls, the line size depends on the estimated maximum number of calls received in an hour and the average length of each call. If NuPoint is used mainly to take messages for internal employees, then the number of lines is a function of the number of employees. This ratio can be anywhere from 20:1 to 100:1 depending on usage patterns.

As an example, assume that the maximum call volume of a site is 500 calls per hour, using a conservative call rate of 10 calls per hour per port, 50 ports would be needed to minimize busy calls.

MINIMUM SYSTEM SPECIFICATIONS

This section summarizes the specifications for NuPoint UM systems that are supported for the current NuPoint software release.

CPU intensive applications such as G.729a, SN, TTS, Advanced UM, and SAA are not supported on single core micro-processor based servers.

NUPOINT UM 60 SPECIFICATIONS

NuPoint UM 60 is a software-only solution that includes software and documentation. The customer or solution provider is required to purchase one of the MSL qualified server platforms directly from the server vendor.

NuPoint UM 60 is supported on entry-level or mid-range servers. Refer to the *MSL Qualified Hardware List* available at Mitel OnLine for a list of supported servers.

Table 8. Minimum System Requirements: NuPoint UM 60

CPU (MIN.)	RAM (MIN.)	HARD DRIVE (MIN.)	REMOVABLE MEDIA	EXTERNAL STORAGE
2.0 GHz (min.)	2 GB ¹	80 GB	Internal or USB DVD-ROM	No
Intel Xeon, minimum 2 cores, 2 threads per core, 8 MB of L2 cache.		Recommend S/W or H/W RAID1	Optional Internal diskette drive	
Note: If Speech Navigation is required, then the system hardware must be a server-grade, Dual-Core Intel Xeon CPU with a minimum 2 GB of RAM.				

NUPOINT UM 120 SPECIFICATIONS

NuPoint UM 120 is a software-only solution that includes software and documentation. The customer or solution provider is required to purchase one of the qualified server platforms directly from the server vendor.

Table 6. Minimum system Requirements: NuPoint UM 120

CPU (MIN.)	RAM (MIN.)	HARD DRIVE (MIN.)	REMOVABLE MEDIA	EXTERNAL STORAGE
2.0 GHz (min.)	8 GB ²	300 GB	Internal or USB DVD-ROM	No
Intel Xeon, minimum 2 cores, 2 threads per core, 8 MB of L2 cache.		Recommend H/W RAID5	Optional Internal diskette drive	
Note: If you implement the Speech Navigation feature, a server-grade, Quad-Core Xeon CPU and 16 GB of RAM is required.				

¹ For installations that have a large Speech Auto Attendant name space (>1000), we recommend you use 4GB of RAM in order to avoid performance degradation and to improve speech recognition results.

² For installations that have a large Speech Auto Attendant name space (>1000), we recommend you use 4GB of RAM in order to avoid performance degradation and to improve speech recognition results.

VIRTUAL NUPOINT UM SPECIFICATIONS

Depending on the profile selected, vNuPoint will have different resources reservations as shown below. Existing vNuPoint UM sites (with a maximum of 64 ports) may select the profile most appropriate to their needs.

The following outlines the minimum system requirements for Virtual NuPoint UM.

- Virtual NuPoint UM is designed to run on VMware vSphere 5.5 software, with the VMware vSphere client
 - NPM 7.0 has been qualified against SRM 5.5
 - Only servers listed in the VMware Hardware Compatibility List for the VMware ESXi 5.1 release are supported for the deployment of Virtual NuPoint UM. The server model selected from the VMware Hardware Compatibility List must support the following minimum microprocessor criteria:
 - An Intel-based server with as a minimum a Xeon® 5520 Series processor running at 2.26 GHz or faster, supporting Intel Nehalem architecture, with Intel Virtualization (VT) and hyper-threading enabled
- OR
- An AMD-based server with a minimum Opteron 2300 series processor running at 2 GHz or faster, supporting Rapid Virtualization Indexing technology.

Table 9. Virtual NuPoint UM Deployment Configurations

DEPLOYMENT CONFIGURATION	PORTS	RAM		VCPU		HARD DISK STORAGE	
		TOTAL	RESERVED	TOTAL	RESERVED	SIZE	USED
Mid Market	60*	4 GB	4 GB	2 vCPUs	2000 MHz	130 GB	125 GB
Enterprise	120*	6 GB	6 GB	4 vCPUs	4000 MHz	260 GB	255 GB
Large Enterprise	240	8 GB	8 GB	8 vCPUs	8000 MHz	520 GB	515 GB

* Note that Hyper-V only supports the 60 and 120 port deployment configurations of vNupoint UM; the 240 port version is unsupported. Also note that, as a general rule, Hyper-V requires twice as many vCPUs as VMWare.

MAPI GATEWAY SPECIFICATIONS

Physical MAPI Gateway Hardware and Software Requirements

The NuPoint MAPI Gateway has the following minimum hardware and software requirements:

Table 10. Physical MAPI Gateway Requirements and Capacity (Single Core)

SYSTEM FEATURE	MAXIMUM CAPACITY
Processor Type	single core
RAM	1 GB minimum
Hard Drive Space	80 GB
Operating System	One of: Windows 2012 Server R2 (64 bit) Windows 2008 Server R2 (64 bit) Windows 8 Professional (64 bit) Windows 7 Professional (32 or 64 bit)
Other Software	For Microsoft Exchange Server 2010 SP3 and Exchange 2013 SP1, install the latest version of "Microsoft Exchange Server MAPI Client and Collaboration Data Objects 1.2.1" version 6.5.8309.
Number of Users	2500 max. (irrespective of the number of MAPI gateways that are in use)

Virtual MAPI Gateway Hardware and Software Requirements

MAPI Gateway software could be installed on an existing or new Windows-based server in the customer's VMware environment.

The MAPI Gateway is supported in a VMware ESXi 4.1 or higher virtual environment. It will continue to be delivered as installable software on selected supported Microsoft Windows operating systems. There will not be an Open Virtual Format Archive (OVA) deliverable.

The minimum system requirements for the virtual machine will depend on the operating system selected for MAPI Gateway. The following table identifies the virtual footprint required in terms of virtual CPUs, memory, hard disk, and the number of Advanced UM users for each supported operating system when running in a VMWare ESXi 4.1 or higher virtual environment.

Satisfying the following conditions is the minimum requirement for MAPI Gateway to function at an acceptable level.

Table 11. Virtualized MAPI Gateway Requirements and Capacity

OPERATING SYSTEM	VCPU	MEMORY (GB)	HARD DISK (GB)	# OF USERS
Windows Server 2012 R2 (64 bit)	2	2	32	2500
Windows Server 2008 R2 (64 bit)	2	2	32	2500
Windows 8 Professional (64-bit)	2	2	25	2500

Windows 7 Enterprise, Professional, or Ultimate (32/64 bit)	2	2	25	2500
---	---	---	----	------

MAPI Gateway Software Prerequisites

Before you install MAPI Gateway, please refer to the *NuPoint Unified Messaging System Administration Help* for instructions.

Client Throttling Policy on Microsoft Exchange 2010 SP1

Microsoft Exchange 2010 SP1 includes Client Throttling Policies that are intended to limit the resources and connection bandwidth consumed by individual users. The default policy is too restrictive for customer sites that use MAPI Gateway deployment for Advanced UM because a single [superuser] account manages message synchronization.

Refer to the *NuPoint Unified Messaging System Administration Help* for instructions for setting this value appropriately.

Performance with Exchange 2013

The MAPI Gateway can support a maximum of 2,500 Advanced UM users. If you are near this limit and you are using Microsoft Exchange 2013 as a mail server, your users may experience long delays in synchronizing their Exchange inboxes and NuPoint mailboxes. The only solution to this problem is to reduce the number of Advanced UM users.

Note that this is a known issue with Microsoft Exchange 2013. If your enterprise is using Microsoft Exchange 2010 or earlier, your users should not experience any delay with message synchronization.

SOFTWARE REQUIREMENTS

In order for NuPoint to function correctly, specific versions of various applications and operating systems are required.

- The Admin Web Console (AWC) and Web View have browser requirements
- Advanced UM has email server requirements
- Outlook Plug-in has email client requirements
- MAPI Gateway has operating system requirements

The requirements are summarized in the Application Compatibility Appendix in the *NuPoint UM General Information Guide*.

Adjunct Systems

This section outlines the supported software versions of adjunct systems.

Table 12. Minimum Software Requirements

INTERFACING PRODUCT	MINIMUM SOFTWARE VERSION	REQUIRED FOR THE FOLLOWING FEATURES & FUNCTIONALITY
Mitel MiVoice Business (formerly MCD)	4.0 when implemented with Standalone NuPoint	Dial-Back
	5.0 when implemented with MiCollab NuPoint	Trusted Service Level Application
Dialogic DMG1000	5.0	SIP integration
	6.0	NP Fax
Dialogic DMG2000	6.0	NP Fax

Minimum software requirements for NP-UM integrations on MiCollab differ from the above information, for details refer to the MiCollab Engineering Guidelines.

NETWORK ENGINEERING – IP (PBX) INTEGRATION

This section provides guidelines for integrating the various NuPoint product offerings into IP networks that employ IP PBXs.

To ensure good voice quality on IP networks the Administrator should employ QoS mechanisms, for details refer to the section called maintaining Voice Quality on IP Networks.

Integrating NuPoint into the Network

Figure 1 provides an example of how members of the NuPoint UM family of products should be deployed in the LAN. Since the NuPoint application is VLAN unaware it is important to connect the server to the Access L2 switch as shown so that voice quality is maintained.

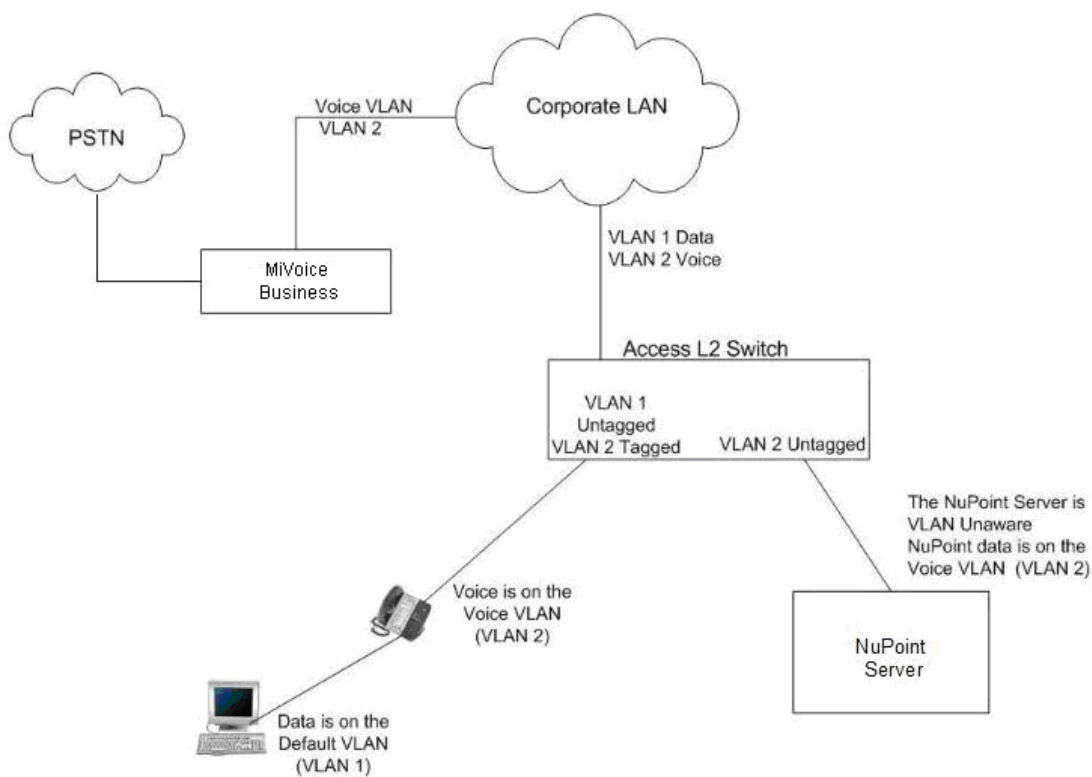

Figure 1. NuPoint UM Deployment

IP BANDWIDTH CONSIDERATIONS

NuPoint is a voice over IP (VoIP) product: each of its ports behaves as a VoIP end point. The following table provides some NuPoint port characteristics.

Table 13. Port Characteristics

PROPERTY	VALUE	DESCRIPTION
Encoding rule	G.711	G.711 is the default CODEC

Optional encoding rule	G.729a	Supported as a licensable option
Encryption	NO	Currently, no encryption is supported
Signaling	SIP or MiTAI/MiNET	One signaling channel per port
Compression	NO for G.711	Currently, no compression is supported

The rule of thumb in allocating IP bandwidth for voice channels is to allocate 100 Kbits/s for each G.711 channel and 40 Kbits/s for each G.729a channel.

You then add a 10% signaling overhead to the bandwidth figure.

The following example illustrates the calculation for G.711 channels:

$$BW \text{ (kb/s)} = 110 \times \text{Number of voice channels}$$

Example: A 120-port NuPoint system requires a peak LAN bandwidth of 13200 kb/s or 13.2 Mb/s, necessitating the use of 100 Mb/s (Fast Ethernet) switches.

MAINTAINING VOICE QUALITY ON IP NETWORKS

Quality of Service

There are two areas where priority mechanisms can operate in the network to ensure that specific types of traffic are treated with higher priority than other types of traffic:

- Layer 2 in the LAN through use of VLANs and packet tagging
- Layer 3 in the WAN through use of DiffServ/TOS/Precedence mechanisms

Layer 2 Priority

The mechanism used for L2 priority is described in the specification IEEE 802.1p. This is a subsection of IEEE 802.1Q also known as VLAN tagging.

IEEE 802.1p (Layer 2 priority) uses a field in the IEEE 802.1Q tag to provide eight levels of priority. IEEE 802.1Q is the open VLAN standard that extends the Ethernet header by adding an additional 4 bytes to tagged packets.

Because the 802.1p priority is part of the VLAN header, ports that need to convey multiple VLANs/802.1p priorities must use tagging.

Layer 3 Priority

Differentiated Services or DiffServ is a L3 QoS mechanism used for classifying network traffic so that Quality of Service can be assured. DiffServ can, for example, be used to provide low-latency to critical network traffic such as voice streaming media while providing simple best-effort service to non-critical services such as web traffic or file transfers.

DiffServ uses the 6-bit Differentiated Services Code Point (DSCP) field in the IP header for packet classification purposes. DSCP replaces the outdated Type of Service (TOS) field.

Differentiated Services uses DiffServ code point values to separate traffic into different classes, these classes are used by routers to determine what the Per Hop Behavior (PHB) of a router hop should be.

NuPoint UM uses the QoS settings shown in the following table for both MiNet and SIP operation. These QoS values are used on packets that are being transmitted from NuPoint to the MiVoice Business or from NuPoint to the IP phone.

Table 14. Quality of Service L3 DSCP Values

Mitel Service Class	L3 DSCP Values
Telephony (Voice)	46 (EF)
Signaling	0 (DF)
Standard	0 (DF)

IP Network Limits

IP networks are asynchronous networks and they are prone to bursts of traffic that may cause some transmitted packets to be lost.

To ensure good voice quality, the network connecting the 3300 ICPs, MiVoice Business servers, and IP phones should comply with the recommendations provided in the following table.

Table 15. Voice over IP: Network Limits

Packet Loss	Jitter	End-to-end Delay	Legend
< 1 %	< 30 ms	< 50 ms	Green = Go
< 5 %	< 60 ms	< 80 ms	Yellow = Caution
> 5 %	> 60 ms	> 80 ms	Red = Stop

To ensure Fax reception quality for Faxes that are carried as G.711 packets, the network between the 3300 ICPs, MiVoice Business servers, and the NuPoint server should comply with the recommendations shown in the following table.

Table 16. Fax over G.711 (Pass Through): Network Limits

Packet Loss	Jitter	End-to-end Delay	Legend
< 0.1 %	< 20 ms	< 300 ms	Green = Go
< 0.2 %	< 40 ms	< 500 ms	Yellow = Caution
> 0.2 %	> 40 ms	> 500 ms	Red = Stop

Automatic Gain Control

Automatic Gain Control (AGC) is a function that is provided for NuPoint by the 3330 ICP. AGC automatically adjusts the audio level of voice calls to ensure that the signal is at an optimum volume level.

The AGC function is most important in cases where calls are arriving on analog (LS) trunks as opposed to digital (PRI) trunks since calls from analog trunks will typically be slightly lower in amplitude than calls arriving on digital trunks.

The default setting for AGC is “Disabled”. Detailed instructions on how to enable AGC can be found in the NuPoint System Administration Help.

Ethernet Packet Rates

NuPoint uses a fixed packet transmission rate of 20 ms. If an incoming call using a different packet rate is streaming to NuPoint, it may result in distorted audio.

To allow NuPoint to accommodate packet rates other than 20 ms, the Administrator should configure NuPoint for Variable Packet Rates. Details can be found in the NuPoint System Administration Help. MiVoice Business supports variable packet rates at Release 4.0 and greater.

Troubleshooting Voice Quality Issues

For information on troubleshooting voice quality issues the Administrator can refer to the following:

- The section of this document called “Speech Tuning and SAA Customization”
- If 3300 ICP analog trunks are involved, refer to the MiVoice Business documentation to verify that the analog trunks are configured correctly. This information can be found in the Technician’s Handbook and System Administrator Tool Online Help available on Mitel OnLine.
- The MiVoice Business Voice Quality Troubleshooting Guide available on Mitel OnLine.

NUPOINT AND SIP INTEROPERABILITY

NuPoint automatically supports Symmetric RTP; no configuration is required by the Administrator to support this capability.

NETWORK ENGINEERING - DIGITAL AND ANALOG INTEGRATIONS

This section provides guidelines for integrating the various NuPoint product offerings into IP networks that employ digital and analog interfaces to the PBX.

NUPOINT STANDALONE DIGITAL/ANALOG SYSTEMS

This configuration is implemented in scenarios where the customer will not be using or deploying VPIM, NP View, NP Admin, SSH, or Unified Messaging/Call Director. When these applications are not in use, there is no need to connect the NuPoint system to the customer's LAN/WAN.

Requirements:

- 100 Base-T Full-Duplex Switch
- Cat5 Ethernet Cables for connection between NuPoint IP, DMG(s), and the switch
- Static private IP Addresses (1 for each DMG and 1 for the NuPoint system)
- DMG line cables for telephony ports

NUPOINT NETWORKED DIGITAL / ANALOG SYSTEM

This configuration is implemented in scenarios where the customer will be using or deploying VPIM, NP View, NP Admin, Telnet, or Unified Messaging. When these applications are in use, the NuPoint system must be networked with the customer's LAN/WAN.

Requirements:

- Available port on the Layer2 Switch
- Cat5 Ethernet Cables for connection between NuPoint IP, DMG(s), and the switch
- Static public IP Addresses (1 for each DMG and 1 for the NuPoint system) – supplied by the customer's IS/IT department
- For Analog SMDI integration, a Serial Cable for SMDI link
- For unified messaging systems, the hostname and IP address of your organization's smart host (Mail Transfer Agent)
- Add your NuPoint server to the DNS forward and reverse lookup zones of your organization. Most SMTP servers will do a DNS resolution on incoming messages. If your NuPoint server does not have a published DNS record, the server may reject the message

ENGINEERING FOR OPTIMUM SYSTEM AVAILABILITY

POWER PROVISIONING

NuPoint Power Provisioning

NuPoint servers should be powered from their own dedicated AC power outlet.

When deploying NuPoint servers it is important to ensure that each NuPoint server is powered from its own dedicated AC power outlet. In cases where a server has redundant power supply units, each power supply should be powered from its own branch circuit.

External storage devices should be powered from their own dedicated AC power outlets.

If a resilient IP phone network has a single power source (not recommended), and if that source fails, all devices will stop working. This should be taken into consideration when designing the network.

If it is required that the critical elements of the network retain power in the event that the main power feed fails: secondary powering schemes need to be in place. This can be accomplished through an alternative power source such as a secondary main supply, local UPS or local generator.

Primary devices, NuPoint, external storage devices and network devices should be powered from a different branch circuit than the branch circuit that is used for powering the secondary devices. This will require special attention if the primary and secondary devices are co-located in the same wiring closet.

If there are any questions regarding whether or not AC receptacles are on separate building branch circuits the Administrator should consult a qualified electrician.

Uninterruptible Power Supply (UPS)

Uninterruptible Power Supplies can range from simple local battery units to larger central installations that include backup generators.

Consider the following factors to determine the type of unit to use:

- The power to be drawn by attached units
- The power output of the UPS, and its efficiency with battery capability
- The time the UPS must supply power
- The size of the unit

America Power Conversion (APC) is a company that designs and sells UPS systems. Some calculations that are useful for sizing UPS systems can be found on the APC web site:

http://www.apc.com/tools/ups_selector/index.cfm

ENVIRONMENTAL CONSIDERATIONS

The System Administrator and installer should check the documentation of the server hardware external storage devices, peripherals, and L2 switches that are part of the NuPoint installation and ensure that the installation site complies with the vendor's environmental requirements for system operation.

Key considerations are:

- Input Power Requirements
- BTU Rating of server
- System Inlet Temperature Range
- Relative Humidity
- Altitude

The System Administrator/installer should verify that the total power requirements and total BTU ratings of the equipment being installed do not exceed the site power and HVAC budget.

MIVOICE BUSINESS RESILIENCY

In the context of NuPoint Unified Messaging, resiliency is the ability for its ports to fail over to a secondary host MiVoice Business when the primary MiVoice Business is down or unreachable, and then to fail back to the primary MiVoice Business when it recovers and the programming allows it to do so. Resiliency is programmed on, and only functions in, systems with MiVoice Business PBXs.

For information about resiliency and programming, refer to the NuPoint Technician's Handbook, the Resiliency Guidelines and the MiVoice Business System Administration Tool Help.

PSTN CONNECTIVITY AND WAN CONNECTIVITY

Guidelines on maintaining PSTN and WAN connectivity are provided in the MiVoice Business Engineering Guidelines and the Resiliency Guidelines. This topic is also discussed in a series of white papers dealing with telephone system availability; these papers can be found on Mitel OnLine.

NUPOINT REDUNDANCY

If system redundancy is required the Virtual NuPoint UM offering which runs in a VMware environment should be considered.

Virtual NuPoint UM can take advantage of the system availability enhancements that are offered by the VMware solution. For details, refer to the "Virtual NuPoint UM" section of this document.

GEOGRAPHICAL CONSIDERATIONS

Some customers may require very high levels of system availability and/or disaster recovery capabilities that can only be achieved when two (redundant) NuPoint systems are located in different geographical locations. If this is the case, then the Virtual NuPoint UM and the VMware Site Recovery Manager (SRM) offering should be considered as a solution.

SRM can manage failover from production datacenters to disaster recovery sites which are based in a geographically different location. SRM can provide RPOs (Recovery Point Objectives) of 15 minutes to 24 hours. For details, refer to "Virtual NuPoint UM" section of this document.

Mitel has published a series of white papers that discuss network design for availability and geographically distributed systems, these white papers can be found on Mitel OnLine in the “Solutions” area.

LAN CONSIDERATIONS

There are a number of network design techniques that can be employed to increase the availability of the LAN, for instance:

- The network can be designed in a hierarchical fashion
- The network can be designed with full mesh L2 switching connectivity
- Spanning Tree or Rapid Spanning Tree can be used to ensure L2 connectivity
- There are routing protocols that can be used to ensure L3 connectivity

For details on these topics and for additional network design guidelines refer to the *Mitel Communications Directory Resiliency Guidelines*, specifically *Appendix A Engineering Guidelines for Resiliency*.

VERIFYING REDUNDANT & RESILIENT OPERATION

Regardless of how carefully a network has been designed for availability, it should be tested to verify that it operates correctly under failure conditions.

The Administrator should do the following:

- Identify all of the components that make up the network, such as: Power distribution, Power back up, L2 resiliency, L3 redundancy, 3300/MiVoice Business resiliency, PSTN and WAN redundancy, and Virtual NuPoint UM redundancy.
- Ensure that he/she understands what will happen if a component fails.
- Before going “live” with the system, perform tests that introduce faults in order to verify that the system behaves as expected.

NETWORK MANAGEMENT AND SNMP

NuPoint has a utility called Alarm Manager that the administrator can use to receive notification of hardware and application-level alarm events. When an alarm event occurs, the system sends an SNMP Trap to an SNMP agent or an email message to a specific email address.

For details concerning how to enable and use the Alarm Manager, plus a complete list of the proprietary NuPoint alarm messages, refer to the NuPoint System Administration Help.

NuPoint offers a proprietary SNMP MIB definitions file which you may compile into your network management system. For more information, see [Appendix B – NuPoint-MIB Module Description](#).

VMWARE INFRASTRUCTURE

VMware® is a corporation that provides an extensive suite of software solutions that allow customers to create a virtual IT infrastructure.

Mitel's virtual products, including Virtual NuPoint UM are intended to run on VMware's virtual infrastructure and leverage the capabilities that VMware provides.

This section provides guidelines that the Administrator and that the installer should take into consideration when planning and/or deploying a Virtual NuPoint UM installation.

For more information about VMware visit VMware's web site:

<http://www.vmware.com/>

Although Virtual NuPoint UM does not limit the number of mailboxes that can be created, there is a practical limit based on traffic and message storage considerations. Unlike physical servers, Virtual NuPoint UM storage cannot be extended with the purchase of larger hard drives. As a result, the ultimate message storage requirements play a comparatively larger role in determining how many mailboxes the Administrator can configure.

SYSTEM PERFORMANCE

- To guarantee the performance specified for Virtual NuPoint UM the overall system CPU usage must not exceed 75% of CPU capacity; in other words 25% of available CPU resources must be maintained as 'head room'. For details, see the Mitel Virtual Appliance Deployment Solutions Guide.
- The disk subsystem must be able to support a sustained data read/write rate of 750 KB/s (Kilobytes per second) or more.
- SAN drives used by Virtual NuPoint UM should use a RAID10 configuration for increased reliability and throughput.
- It is recommended that iSCSI multi-pathing be employed between the SAN and the VMware ESXi host that Virtual NuPoint UM is deployed on.
- Where possible two or more NICs connected to different L2 switches and a separate storage VLAN is recommended.

SUPPORTED VCENTER MANAGEMENT CAPABILITIES

The VMware vCenter Server provides a scalable and extensible platform that forms the foundation for managing the VMware vSphere environment. vCenter provides IT managers with centralized control and visibility at every level of the virtual infrastructure.

For specific information related to VMware and VMware's product offerings refer to:

<http://www.vmware.com/products/vcenter-server/overview.html>

VMware offers solutions for disaster recovery and enhanced system availability (such as vMotion and Site Recovery Manager), plus other features that enable Mitel customers to leverage their investment in the Virtual NuPoint UM. For more information, see the Mitel Virtual Appliance Deployment Solutions Guide.



Note: To deploy Site Recovery Manager capability with Virtual NuPoint UM, Mitel Professional Services must be purchased. Please request a quotation for SRM support from Services Solutions at the following URL.

<http://domino1.mitel.com/mol/servsol.nsf/ServSolApp?OpenForm>

BACKUP AND RESTORE



Note: Only one backup should be running at a time. Allow time for any scheduled backup to complete before scheduling or running any other backup.

Table 17. Virtual NuPoint UM Backup & Restore Methods

BACKUP/RESTORE REQUIREMENT	RECOMMENDED METHOD:
Day-to-day backup for application data recovery	From most- to least-recommended, only one method to be used: 1 – NPM backup (scheduled) 2 – VMWare Data Recovery (scheduled) 3 – Third-party backup software using VADP if available 4 – Export/Import OVA
NPM Software Upgrade	NPM backup
Re-Deploying a new version of vNPM with a new release	NPM backup
Migration from physical NPM to vNPM	NPM backup

CONVERTING FROM PHYSICAL NUPOINT TO VIRTUAL NUPOINT UM

If you are running a physical NuPoint system and wish to upgrade to Virtual NuPoint, please refer to Mitel Technical Bulletin on the subject of "Migrating Physical 640 NuPoint systems to Virtual NuPoint".

SYSTEM NAMING RESTRICTIONS

To integrate successfully with some VMware features, the name given to the Virtual NuPoint UM Virtual Machine (VM), and VMware datastore names used by Virtual NuPoint UM should not include spaces.

Virtual NuPoint VMs should not be renamed after deployment.

For more information, see the Mitel Virtual Appliance Deployment Solutions Guide.

E-MAIL INTEGRATION

NuPoint UM provides seamless integration with a number of email platforms include hosted email platforms such as Gmail and Office 365.

A presentation package on Hosted Email deployment can be found at Mitel Online under Products/Applications/Unified Messaging.

SMTP AND STANDARD UM

SMTP forwarding provides no synchronization of MWI.

NuPoint Standard UM is easier to deploy than Advanced UM, while still providing key functionality such as turning off the MWI when a message has been accessed from the email client by clicking on the NuPoint UM Audio Link in the email message.

NuPoint UM supports SMTP and Standard UM integration with hosted email providers with a variety of architectures.

For customers who continue to maintain an SMTP server in their network or use an SMTP relay service, NuPoint UM will continue to send mail through those channels.

For all other customers, NuPoint UM offers the following options for sending SMTP email out through the firewall to hosted email service providers and other external email addresses.

MSL(Mitel Standard Linux) contains fully functional SMTP server software, which can deliver mail directly via the Internet through the organization's firewall on port 25. The MSL SMTP server is an industry-standard, reliable, and secure mail transfer agent which is widely used to deliver mail over the Internet. This configuration can be used for integration with hosted email service providers such as Google Mail, Exchange On-line and Office 365. In this case, the MSL SMTP server requires access through the organization's firewall so appropriate security policies and rules must be in place—just as they would have been for an on-premises email server. With this type of access NuPoint UM can continue to send an unlimited volume of mail to users on hosted email services

Alternatively, NuPoint UM can provide authenticated access to hosted email services. This type of access is subject to email send limits defined by the hosted email service provider. The send limits apply to all outgoing mail including alarm notifications and other non-user related email from the NuPoint server. For example, if the send limit is 10,000 messages per day, then the hosted email server will send up to 10,000 messages per day from the NuPoint server to all user. Behavior once the send limit is exceeded is defined by the hosted email service provider, and should be taken into consideration if using this access method. NuPoint UM provides:

- Authenticated access via SSL on port 465. This is used by Google Mail.
- Authenticated access via TLS on port 587. This is used by Office 365 and Hosted Exchange

ADVANCED UM

NuPoint UM supports Advanced UM integration with Google Mail. UM integration with hosted email service providers can be challenging since the customer and the partner have little visibility or control over the email network.

One aspect that should be considered specifically is the message send limit imposed by the hosted email server. For Advanced UM, the send limit applies to individual UM users. For example, if the send limit is 10,000 messages per day then each NuPoint UM user can send up to 10,000 email messages per day.

Deploying a NuPoint System with Advanced UM

Prior to configuring the Advanced UM feature, the System Administrator should ensure that:

- The email server is installed according to the Manufacturer’s recommended installation procedures and tested at the customer site.
- A desktop email client is installed according to the Manufacturer’s recommended installation procedures and tested at the customer site.
- For sites using Exchange/Outlook, an Outlook Plug-in (OCP) is available for the MS Outlook versions listed below.

These tasks will help ensure the Advanced UM components can be installed correctly.

Table 18. NuPoint Advanced UM Requirements/Compatibility

VARIANT	REQUIREMENTS/COMPATIBILITY
NuPoint Advanced UM with IMAP Server	The following email servers are supported: <ul style="list-style-type: none"> • Exchange Server 2010 SP3 • Exchange Server 2013 SP1 • Exchange Server 2016 • Gmail • Microsoft Office 365
NuPoint Advanced UM with MAPI or vMAPI Gateway	The MAPI Gateway software can be installed on a computer with any of the following operating systems: <ul style="list-style-type: none"> • Windows 7 Professional, Enterprise, and Ultimate (32 and 64 bit) • Windows 8 Professional (64 bit) • Windows Server 2008 R2 (64 bit) • Windows Server 2012 R2 (64-bit)

Outlook Client Plug In (OCP)

The following email clients support the Outlook Client Plug-In (OCP):

- 32- and 64-bit bit variants of Outlook 2010 on Windows 7.
- 32- and 64-bit bit variants of Outlook 2013 on Windows 7.
- 32- and 64-bit bit variants of Outlook 2016 on Windows 7 and Windows 10.

Note that the OCP for Outlook 2010/2013/2016 provides slightly different features than the previous versions. The OCP for Outlook 2010/2013/2016 adds a “ribbon” which enhances the user interface and availability of call me/meet me is limited to “confidential” messages.

The OCP is available on all versions of NuPoint UM including NuPoint UM on MiCollab.

SPEECH AUTO ATTENDANT

Speech Auto Attendant (SAA) directs calls to the intended party (or their mailbox) by recognizing caller inputs such as spoken names, digits or department names, or DTMF digits. SAA can be used by both internal and external callers, and employs dedicated Voice User Interface ports.

SAA can be installed with all versions of NuPoint, including NuPoint on MiCollab, or as a standalone application without NuPoint on an entry-level server selected from the *MSL Qualified Hardware List*.

The SAA directory can store up to 10,000 names with up to 4 contact numbers for each user. SAA can also recognize up to 15 department names. Optional licenses for SAA Corporate Directory allow the number of supported directory names to be purchased in increments of 1, 10, 50 and 2000.



Note:

- Languages and combinations of languages that can be recognized by SAA are specified in Appendices in the *NuPoint General Information Guide*.
- If NuPoint UM is installed without SAA, users will not be able to direct calls with spoken instructions. Only DTMF dialing will be supported.
- The standalone version of SAA runs without any of the voicemail features that are included in NuPoint. Existing NuPoint properties displayed in the NuPoint tab (NuPoint User, Mailbox number, Extension number, Pin, FCOS, LCOS, Message Waiting Types and E-mail addresses) will be disabled when SAA is installed as a standalone application.

SAA PORT ESTIMATES

If detailed information to calculate the number of ports required is not available, the following guidelines may be used as a starting point. Additional ports may be purchased as required.

SAA supports a maximum of 30 voice user interface ports (channels). The following rules of thumb can be used to determine the number of SAA voice user interface ports that are required to support a company with a specific number of users.

- 200 users will require 1 voice user interface port
- 400 users will require 4 voice user interface ports
- 1000 users will require 8 voice user interface ports



Note: A more precise method of determining the number of SAA ports (channels) required for a particular application is provided in the “SAA Port Requirements” section of this document.

SAA PORT REQUIREMENTS

SAA ports (Voice User Interface ports) are a licensable option with a maximum of 30 ports. The Administrator or Installer must determine how many ports are required prior to installing the system.

Consider the following factors when you size the number of SAA ports to be licensed and configured:

- **Expected call volume (V)** – The maximum number of calls that SAA is expected to handle, expressed in Calls Per Hour (CPH).

- **Call Mix (M)** – An estimate of the proportion of calls that would be placed by internal callers. This should include an estimate of the number of external or internal non-trusted calls that would be placed by automatons using DTMF to request call transfers via SAA, as the duration for those calls is very short.
- **Typical call durations (D_i, D_x)** - Since internal, trusted callers are usually familiar with the SAA feature and receive truncated prompts when they use it, their call durations are shorter than that of external or internal non-trusted callers. In the formula below, the parameter used to represent internal call duration is D_i. When Bilingual SAA is used, external or internal non-trusted callers are presented with announcements and guidance in both languages: the call durations are longer than in a Unilingual system. In the following formula, the parameter used to represent external call duration is D_x. In addition, the length of custom system announcements will affect the duration of external calls.

Typical call durations are as follows:

- Internal Trusted Caller: 10 sec (D_i)
- Unilingual, External or Internal non-trusted: 20 sec (D_x)
- Bilingual, External or Internal non-trusted: 30 sec (D_x)

You can use the SAA Port Allocation Worksheet to determine the appropriate number of SAA ports for a system. After you complete the worksheet, the following formula will provide an estimate of the number of ports (P) that should be rounded up.

$$P = \frac{V \times (D_e) + M \times (D_i + D_x)}{3600}$$

Table 19. SAA Port Allocation Worksheet

FACTOR	EXAMPLE	CUSTOMER PROVIDED
Expected Call Volume (V)	1000 CPH	CPH
Call Mix (M)	75% Internal	% Internal
Typical Call Durations		
Internal (D _i)	10 sec	Sec
External (D _x)	20 sec	Sec
$P = \frac{1000 \times (20 - 0.75 \times (20 - 10))}{3600} = 3.4 \approx 4$		P =



Note: If you apply the above formula to fax transmissions, bear in mind that a typical three-page fax has a call duration of approximately 90 seconds. However, some customers may send or receive very long faxes and this increased call hold time should be considered.

SPEECH AUTO ATTENDANT GUIDELINES

This document provides Engineering Guidelines for the standalone version of SAA and for SAA when installed in conjunction with NuPoint. The *MiCollab Engineering Guidelines* provide engineering guidelines for SAA running on MiCollab.

Line Groups for SAA

In order to configure lines to use speech recognition applications, the Administrator needs to create line groups in a way similar to creating other line groups on the system. The “Speech Recognition” line group application will not be available if the system has not previously been licensed to perform speech recognition and if SAA is not installed on the system. Similarly, the web interface will not allow the Administrator to create more lines than have been licensed.

Phone Books and Active Directory

When SAA is installed along with NuPoint, SAA leverages the NuPoint infrastructure to look up user names. Alternatively, SAA can use an Active Directory connection to look up user names.

The standalone version of SAA requires either an Active Directory connection or a NuPoint voice user interface port license to look up user names.



Note: If SAA standalone is being installed on a site that does not currently have an Active Directory server, then a single NuPoint voice user interface port license must be purchased so that SAA can perform user name lookups in the phone book. This NuPoint voice user interface port allows the Administrator to create a name database (phone book) by creating mailboxes for all of the users.



Note: The requirement to use an Active Directory server as the SAA phone book is flagged to the Sales Engineer in the Sales Work Bench (SWB) tool when he or she queries the “Speech Presence information” found in the Sales Work Bench.

Integrating SAA into the Network

The following Figure provides an example of how the SAA application server should be deployed in the LAN. Since the SAA application is VLAN unaware, it is important to connect the SAA server to the Access L2 switch as shown to maintain voice quality.

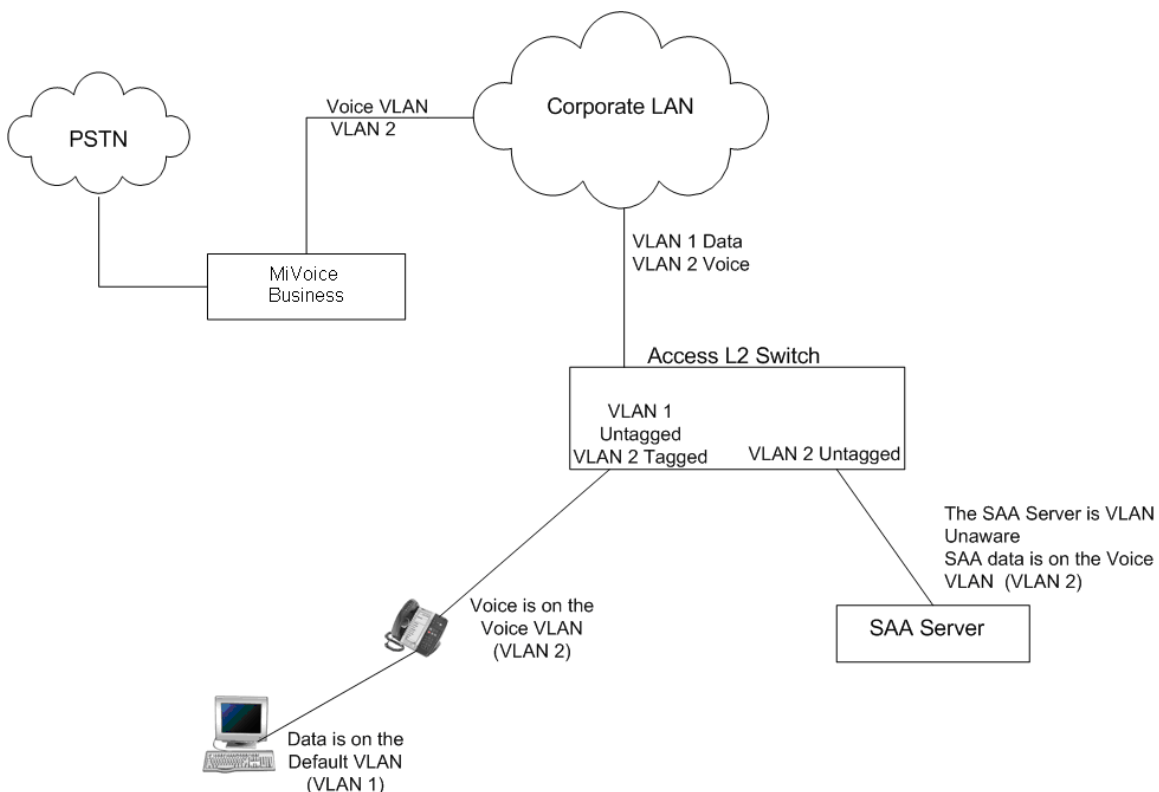

Figure 2. SAA Deployment

SAA Dialing Plan

In order to prevent users from using the SAA feature as a long distance call proxy, dialing policies allow the Administrator to program rules and determine which numbers can be dialed from SAA. The dialing policy also allows numbers to be rewritten before the system places the call. Refer to the *NuPoint System Administration Help* on Mitel Edocs (<http://edocs.mitel.com>) for more information on how to set up the dialing policy.

Setting up correct dialing policies can be complex and it is recommended that the Administrator test the policies first before making them effective. In order to do this, you can type a phone number in the field labeled “Enter a phone number to test” and click the “Simulate” button. The result (the call type and the resulting number that would be dialed) will be displayed next to the “Simulate” button.

SAA Backup and Restore

The SAA user data source configuration, departments, dialing policies, miscellaneous parameters, and line group configuration will be picked-up automatically by the current NuPoint backup and restore procedure.

On standalone SAA systems, the Administrator will perform the backup and restore using the same text-console menus. Options to back up/restore, messages and fax cover pages will not be presented to the Administrator on standalone SAA systems. The same backup/restore strategies (USB, LAN FTP, MS networking to an external or internal hard drive), will be offered to the Administrator.

When SAA is configured to use Active Directory as its user data source, the backup and restore function does not back up (or restore) any information stored in Active Directory.



WARNING: Failure to properly back up Active Directory can result in data loss.

Speech Tuning and SAA Customization

Basic speech recognition parameters employed by SAA will be shared with all of the speech recognition applications hosted on the NuPoint system. In installations that employ two servers, speech-tuning parameters will be automatically propagated to the second server.

Customers can customize the SAA internal/external announcement prompts, dialing plans, and operator transfer destinations. The end user can select the device destination for call transfer (in cases where a user has multiple phone devices).

SAA handles speech ambiguity in the data source for callers with duplicate first/last names by transferring the callers (internal/external) to the operator.

The following speech-related parameters are presented via the web console interface to allow for system tuning to fit into a specific customer's environment. By default, these parameters are already fine-tuned with optimal values as part of SAA installation. However, if the Administrator needs to further adjust these values, it is recommended to consult with Mitel speech experts first

Low Recognition Confidence Level

This value specifies the relative confidence level below which speech recognition results are rejected. The minimum value is 0 and the maximum value is 1, with a two-digit precision. The default value is 0.5.

High Recognition Confidence Level

This value specifies the relative confidence level above which speech recognition results are implicitly confirmed. The minimum value is 0 and the maximum value is 1, with a two-digit precision. The default value is 0.8.

No Speech Timeout

This value specifies the length of silence that will trigger help prompts to be played to users. The minimum value is 0 and the maximum value is 60,000 milliseconds. The default value is 10,000 milliseconds. This value can be tuned to 20,000 milliseconds if the customer site runs into issues with external callers experiencing a high rate of mis-recognition (1000ms = 1 s).

Post-Speech Silence

This value specifies the length of silence that must follow an utterance before the speech recognition engine begins to process it as a complete sentence: the higher the value is, the longer the pauses

allowed from users. The minimum value is 0 and the maximum value is 60,000 milliseconds. The default value is 1000 milliseconds.

Output Volume

This value specifies the linear volume that is applied to the output signal before prompts are played back to users. The Administrator can use this parameter to adjust the volume when the signal played to users is too weak or too loud. The minimum value is 0.0 and the maximum value is 100.0. The default value is 100.0.

Speech versus Accuracy

This value specifies the relative priority of speech versus accuracy. Using high accuracy algorithms requires more CPU resources and thus limits the number of concurrent speech recognition sessions. The minimum value is 0.0 and the maximum value is 1.0. Entering “0.0” places the emphasis on speed, while entering “1.0” places the emphasis on accuracy. The default value is 0.5.

Sensitivity

This value allows you to configure the level between background noise and speech, and thus controls the sensitivity of the speech detector. The minimum value is 0.00 and the maximum value is 1.00. Values approaching 1.00 improve the detection of speech but also increase the detection of background noise and thus utterances need to be spoken with a strong voice so as not to be mistaken with background noise. The default value is 0.50.

Barge-in

This field allows you to enable or disable barge-in for the entire speech recognition engine (that is, SAA and all other installed speech recognition applications). Barge-in is enabled by default.

SAA Name Recognition Problems

In the event that SAA is having problems reliably recognizing names, the Administrator should consult NuPoint System Administration help for troubleshooting information. If 3300 ICP analog trunks are involved the Administrator should also refer to the MiVoice Business documentation for information on verifying that the analog trunks are configured correctly.

SUPPORT FOR G.711 FAX, T.38 FAX AND G.729A COMPRESSION

This section covers the following subjects:

- How to transmit a Fax call to a NuPoint system over an IP network via G.711 packets - G.711 pass-through.
- How to configure the network and the 3300 ICP so that the 3300 ICP provides support for T.38 Fax.
- How to configure the network and the 3300 ICP so that the 3300 ICP provides support for G.729a compression.
- NuPoint includes a licensable option that allows NuPoint to offer on-board support for G.729a compression;.

G.711 FAX

G.711 Fax pass-through refers to the process of transmitting Fax calls over an IP network via G.711 packets.

Sending G.711 pass-through faxes in voice channels over a congested IP network can be problematic. Impairments that may be tolerated in a voice conversation can lose Fax data, causing a Fax transmission to fail.

To successfully implement a G.711 Fax-over-IP solution, you must meet the following network performance parameters.

- End to end delay less than 300 ms
- Packet loss rate no greater than 0.1%
- Jitter less than 30 ms; ideally no more than 20 ms



Note: We strongly recommend that you use full-duplex switched equipment rather than hubs to achieve these performance parameters.

We don't recommend you send Fax tones over IP trunks within MiVoice Business clusters because echo cancellers can affect Fax tones. We recommend that the MiVoice Business interfacing with the NuPoint system has TDM trunks or lines connecting to the Fax device at the far end.

The strict requirement of jitter less than 30 ms means that interfacing equipment, such as Mitel 3300 ICPs or Intel gateways, support fixed jitter buffers. The MiVoice Business automatically switches to a fixed jitter buffer from an adaptive jitter buffer (AJB) when incoming Fax tones are detected.



Note: NP Fax works best with Fax machines that support native V.17 standard.

NuPoint Fax Printer

The NuPoint Fax Printer Driver is supported on Windows-based PCs only. The supported OS versions are detailed below.



Note: Users must have Admin privileges on the host computer to install this software. For more information about NuPoint Fax Printer Driver, see the *NuPoint Unified Messaging User Guide*.



Note: We support fax with Windows 7, but Windows 7 has some limitations. When opening .TIFF files using Photo Viewer or Microsoft Paint from Windows 7, you may see horizontal black lines running through the image. Opening the image in other applications does not display horizontal black lines running through the image. However, saving the image using Photo Viewer or Microsoft Paint from Windows 7 will save the horizontal black lines permanently to the image. This is a known issue in Microsoft Windows 7 Photo Viewer and Microsoft Paint.

Table 20. NuPoint Fax Printer Supported OS Versions

WINDOWS VERSION	NOTE
XP	32-bit
Vista	32 or 64-bit
Windows 7	32 or 64-bit

T.38 FAX AND G.729A COMPRESSION - AN OVERVIEW

What is T.38 and Why is it Required?

T.38 is the protocol recommended by the ITU that allows for the transport of real-time Group 3 Fax transmissions over IP networks.

On very tightly controlled LANs, G.711 packets can be used to transport faxes over an IP network. This is called G.711 Fax pass-through. However, G.711 Fax pass through does not perform well under impaired network conditions. In fact, under some LAN conditions it will not work at all.

T.38, on the other hand, is designed to transmit faxes over IP networks in real time, even under impaired network conditions.

Customers require T.38 if they want to transport faxes over IP networks with confidence. Customers, such as law offices, who require real-time transmission of faxes with real-time acknowledgement that faxes are received by called parties also require T.38.

T.38 gateway functionality can be integrated into some of the 3300 ICP platforms. T.38 functionality is also supported in some third party SIP gateways. T.38 capable Fax machines are present in the marketplace.

T.38 is supported on the following ICP platforms:

- 3300 MXe
- 3300 CXi
- 3300 CX
- 3300 AX

To support T.38 with NuPoint, the 3300 ICP must be configured specifically with a DSP II MMC card and T.38 licenses must be enabled.

For additional information on configuring the 3300 ICP to support T.38, refer to *the 3300 ICP Engineering Guidelines*.

What is G.729a and Why is it Required?

G.729a is the name of a voice CODEC that can be used to save bandwidth while still maintaining good voice quality, especially over restricted WAN connects

The word CODEC is a concatenation of two words: Coder and Decoder.

The CODEC performs two functions—coding and decoding—for the conversion of media. In this case, it converts voice into some data format that can be transported over a digital communication link and returned at the far end into something akin to the original.

For voice, this usually involves converting the analog signals into digital signals and levels and returning them back to analog.

- Mitel currently negotiates the following CODECs in IP telephony:
- G.711
- G.729a
- G.722.1

The G.711 CODEC provides the best voice quality and music on hold quality (but at the expense of more bandwidth) and is comparable to TDM-type connections.

G.729a provides a good reduction in bandwidth with only minor loss in voice quality.

G.711 is used where bandwidth is available, such as in LAN environments. G.729a is used in WAN access environments, where bandwidth is not so readily available.

G.722.1 is used to support wide band audio.

The type of CODEC that is selected for a particular connection depends on a number of issues, including the:

- Voice quality expected by the user
- Available bandwidth, especially on a WAN link
- Number of devices on a link, and how many are active based on traffic patterns
- Zone programming on the 3300 ICP
- IP trunk programming on the 3300 ICP

EMBEDDED G.729A SUPPORT

NuPoint includes on-board or embedded support for G.729a compression. Note that prior to software release 6.0, G.729a compression could only be supported with a 3300 ICP acting as a gateway for NuPoint. The gateway provided G.729a support.

Using a 3300 ICP to support G.729a is discussed under Using a 3300 ICP Gateway to Support T.38 and/or G.729a.

Embedded G.729a functionality is a licensable option and it is available on all versions of NuPoint UM including NuPoint UM on MiCollab.

G.729a is licensed on a per system basis, NuPoint systems that are not licensed for G.729a will continue to use G.711 CODECs for all calls.

- G.729a is enabled by line group
- Fax line groups do not support G.729a and G.729a support will be automatically disabled.

The use of G.729a can allow for a significant cost savings since G.729a requires 40 kb/s of bandwidth compared to the 100 kb/s requirement for G.711.

G.729a calls provide a slightly lower audio quality and require more processing power than G.711 calls.

USING A 3300 ICP GATEWAY TO SUPPORT T.38 AND/OR G.729A

NuPoint does not support T.38 Fax natively, however a 3300 ICP can be configured as a gateway to provide support for T.38.

In some cases the Administrator may not have purchased the NuPoint G.729a license or the Administrator may not have provisioned all line groups with G.729a support. If necessary a 3300 ICP can be configured as a gateway to provide support for G.729a compression.

This section provides the information that relates to supporting T.38 and G.729a on a 3300 ICP that is acting as a gateway to the NuPoint server.

Overview

When a 3300 ICP is used as a gateway to provide NuPoint with T.38 or G.729a support, the network and 3300 ICP configuration is handled in the same fashion.

This support is achieved by placing a T1 card on the 3300 ICP into loopback mode.

All calls must terminate on the 3300ICP, which then provides gateway functions into NuPoint. The 3300 ICP and NuPoint should be in the same network zone. Also, the 3300 IPC and NuPoint should ideally be located in the same L2 subnet.

T.38

When a T.38 call is placed to the NuPoint server, the T.38 call will terminate on the 3300 ICP as a T.30 fax call. The T.30 Fax call is then routed in TDM form via the back-to-back T1 trunk and is then converted back to G.711 fax pass through and sent on to the NuPoint server. It is necessary to have a dual T1/E1 card installed in the 3300 ICP. A loopback cable is used to connect the two ports of the T1/E1 card together. Using ARS, with digit insertion and removal, the Fax call is directed out the T1 link and then sent on to the NuPoint server.

G.729a

When a G.729a call is placed to the NuPoint server, the G.729a call will terminate on the 3300 ICP. The call will then be routed in TDM form via the back-to-back T1 trunk and is then converted back to G.711 and sent on to the NuPoint server as a G.711 call. Ensure you have a dual T1/E1 card installed in the 3300. A loopback cable connects the two ports of the T1/E1 card together. Using ARS, with digit insertion and removal, the call is directed out the T1 link and then sent on to the NuPoint server.

T.38 & G.729a Configuration Details

As mentioned in the preceding section, a 3300 ICP Gateway needs to be deployed to provide T.38 and/or G.729a support for the NuPoint system.

There are numerous 3300 ICP platforms and the 3300 ICPs can be configured in a multitude of different ways. This document does not attempt to describe all of the possible 3300 ICP Gateway configurations; instead this document describes the largest possible 3300 ICP Gateway configuration. The gateway configuration described here will provide support for 90 NuPoint Voice User Interface (VUI) ports.

If the NuPoint installation requires support for more than 90 VUI ports, then multiple 3300 ICP gateways will need to be deployed. If the NuPoint installation requires support for less than 90 VUI ports, then you will need to refer to the MiVoice Business product documentation and the MiVoice Business System Engineering Tool to determine an optimum gateway configuration.

Maximum Size Gateway

The MXe Controller 192 Gateway illustrated below can be used to provide G.729a support and T.38 Fax support to a NuPoint system. This configuration provides support for up to 90 voice user interface ports on NuPoint. If support for more than 90 NuPoint ports is required, then multiple MXe 192 gateways will need to be deployed.

The three Dual E1 MMCs provide 6 E1 digital links which can be used to implement trunk loopbacks so that G.729a or T.38 calls can be terminated on the MXe. These calls will then be routed from the MXe to the NuPoint server via G.711 packets.

The 6 E1 digital links provide 180 trunks or channels; however, looping back the trunks means that a total of only 90 trunk loopbacks can be provided by the MXe 192 gateway.

The DSP II MMCs can provide 8 channels of T.38 support and 192 channels of G.729 support.

In summary, this configuration will provide:

- 90 trunk loopbacks so that up to 90 G.729 calls can be terminated on the MXe and routed to up to 90 voice user interface ports on NuPoint as G.711 calls.
- 8 channels of T.38 support so that up to 8 T.38 calls can be terminated on the MXe and then be routed to NuPoint as G.711 pass through calls to up to 90 combo mail boxes on NuPoint.



Note: NuPoint can simultaneously support 6 T.30 entities (virtual Fax machines).

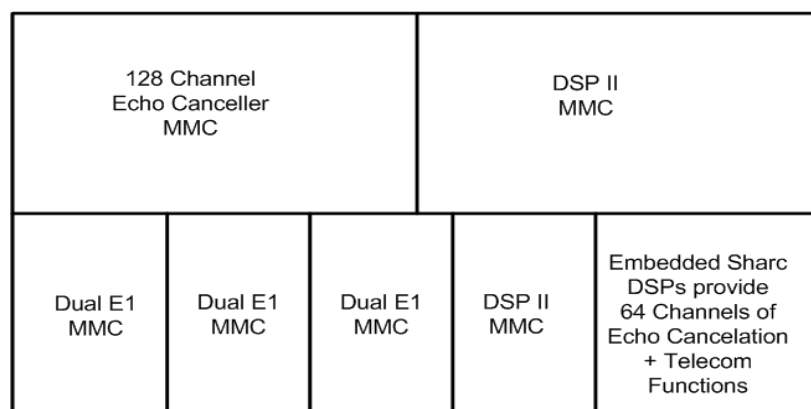

MXe III Controller 192 Gateway

Figure 3. MXe III 192 G/W

Call Routing Detail

This section provides an overview of how T.38 and G.729a calls can be routed through a customer's network.

The Administrator and/or installer should carefully consider where T.38 gateway capabilities are required to support ingress and egress from the T.30 domain to the T.38 domain and vice versa.

Once the relevant 3300 ICPs have been identified, it will then be necessary to properly configure and license these 3300 ICPs.

For details on configuring and licensing T.38 on a 3300 ICP, refer to the MiVoice Business product documentation.

T.38 Call Routing – Fax Originating on a User Gateway

While referring to the following figure it can be seen that:

- The Application Gateway terminates the T.38 portion of the Fax call.
- The G.711 stream carrying the Fax data is routed out of a T1 trunk and back into a T1 trunk and then routed to the NuPoint server.

The detailed end-to-end steps for this call are as follows:

1. The originating Fax is on the User Gateway.
2. The Fax call is carried as TDM traffic until arriving at the User Gateway.
3. The User Gateway converts the Fax call from TDM to T.38.
4. The Fax call is carried as T.38 from the User gateway to the Application Gateway.
5. At the Application Gateway the T.38 call is converted to TDM.
6. The call is then routed over the T1 loopback and then routed to NuPoint as a G.711 pass through call.

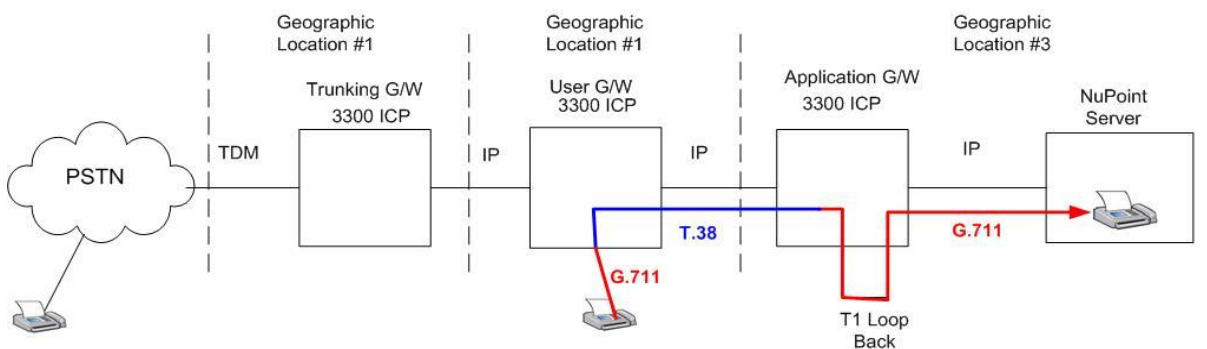

Figure 4. Fax Call, User G/W to NuPoint

T.38 Call Routing – Fax Originating on the PSTN

While referring to the following figure it can be seen that:



Note: The Application Gateway terminates the T.38 portion of the Fax call.



Note: The G.711 stream carrying the Fax data is routed out a T1 trunk and back in on a T1 trunk and then routed to the NuPoint server.

The detailed end-to-end steps for this call are as follows:

1. The originating Fax is on the PSTN.
2. The Fax call is carried as TDM until arriving at the Trunking Gateway.
3. The Trunking Gateway converts the Fax call from TDM to T.38.
4. The Fax call is carried as T.38 to the Application Gateway. The Fax data does not actually pass through the User Gateway; however, signaling for call set up may pass through the User Gateway.
5. At the Application Gateway the T.38 call is converted to TDM.
6. The call is then routed over the T1 loopback and then routed to NuPoint as a G.711 pass through call.

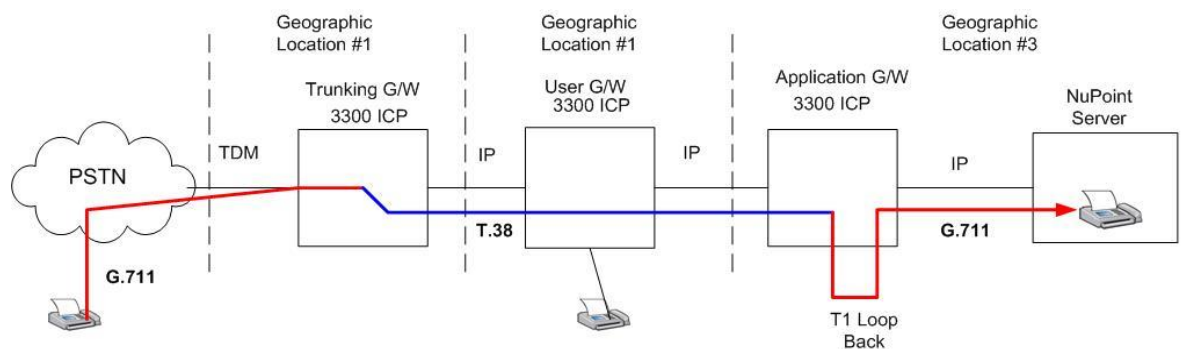

Figure 5. Fax Call, PSTN to NuPoint

G.729a Call Routing to NuPoint

The following figure illustrates how a G.729a call might be routed towards a NuPoint server.

1. The originating call is from an IP phone that is connected to the User Gateway. This leg of the call is carried in G.711 packets.
2. To save on bandwidth the Administrator has decided to use G.729a compression on the IP trunk connecting the User Gateway to the Application Gateway.
3. Since NuPoint does not support G.729a compression natively, the Application Gateway must terminate the G.729a leg of the call. Then, using ARS with digit insertion and removal, the call is directed out the T1 link and then sent on to the NuPoint server.

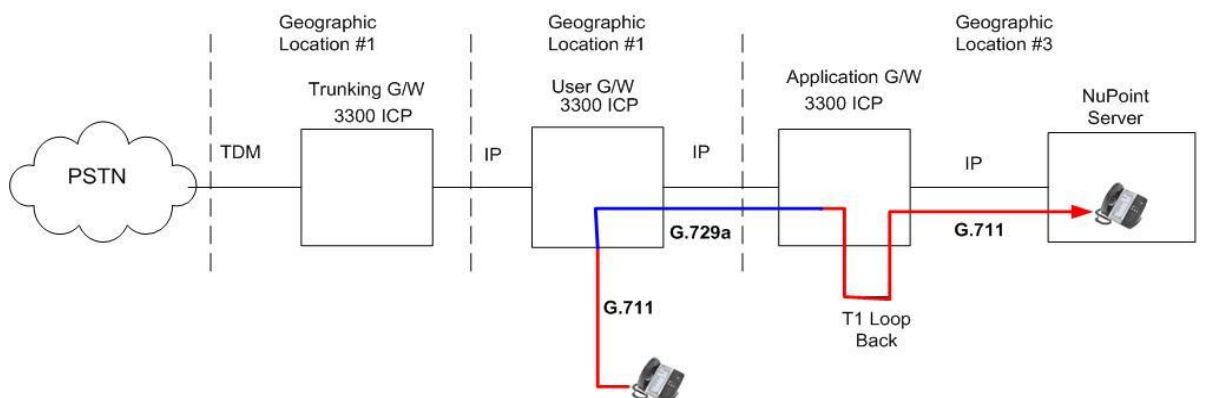

Figure 6. G.729a Call to NuPoint

UPGRADES AND MIGRATION

PHYSICAL NUPOINT

There are two upgrade options you can perform on NuPoint software versions:

- **Upgrading with the same MSL version:** this means that both the operating system (MSL) and the NuPoint software can be upgraded: neither requires a fresh installation.
- **Upgrade with a new MSL version:** this means that the NuPoint software for this release operates on a new release of the operating system software (MSL). The "rebuild" procedure (including a fresh MSL installation) is required for these versions.



Note: When upgrading a NuPoint UM 120, you must rebuild the server and perform a fresh MSL installation.

Refer to the *NuPoint Unified Messaging Release Notes* to determine which option is required for a particular release. Refer to the *NuPoint Unified Messaging Technician's Handbook* for detailed upgrade procedures and instructions for migrating data from previous releases.

UPGRADING VIRTUAL NUPOINT UM

There are two upgrade options you can perform on Virtual NuPoint UM software versions:

- **Converting a Physical Server DB to Virtual NuPoint UM:** this involves converting a NuPoint Standard or Single Server database to a Virtual NuPoint UM deployment using the Restore option in the server console.
- **Upgrade with an OVA file:** this involves installing a new NuPoint OVA file and restoring the MSL and NuPoint backups. This procedure should be used for all operational Virtual NuPoint UM systems.

Refer to the *NuPoint Unified Messaging Technician's Handbook* for detailed upgrade and migration procedures.

APPENDIX A – NUPOINT PORTS

Table 21. NuPoint Ports Descriptions

IP PORT NUMBER	TRANSPORT	NOTES	FUNCTION
20	TCP	From LAN	FTP (Data)
21	TCP	From LAN	FTP (Control)
22	TCP	To LAN	SSH Remote Login Protocol (“putty”), AMC Registration
25	TCP	To/From LAN	VPIM / SMTP
53	TCP	To LAN	DNS
80	TCP	From LAN	HTTP
123	TCP/UDP	To LAN	NTP
143	TCP/UDP	To LAN	IMAP / MAPI Gateway (TLS)
161	UDP	From LAN	SNMP
162	UDP	To LAN	SNMP-Trap
389	TCP	To LAN	LDAP
443	TCP	From LAN	HTTPS
465	TCP	To LAN	Secure SMTP (SSL)
587	TCP	To LAN	Secure SMTP (TLS)
636	TCP	To LAN	LDAPS (SSL)
777	TCP	To/From LAN	NuPoint Net
993	TCP/UDP	To LAN	IMAP / MAPI Gateway (SSL)
34597	TCP/UDP	To LAN	Secure SoapServer (SSL)
34598	TCP/UDP	To LAN	SoapServer
34599	TCP/UDP	To/From LAN	FAX printer driver
5001 to 5006	TCP/UDP	To LAN	ESMDI
5060	TCP/UDP	To/From LAN	SIP (Proxy) (always present; NuPoint UM Standalone configurations only)
5071 to 5310 Port = 5071 + channel number, where channel number is 0 to 239.	TCP/UDP	To/From LAN	SIP Channels. The initial contact is through port 5060. Subsequent contact is through port 5071 to 5310 (240 Channels)

IP PORT NUMBER	TRANSPORT	NOTES	FUNCTION
5444	TCP	From LAN	Database admin (CLOSE in firewall)
50000 to 50479 See Note 1	UDP	To/From LAN	Voice Communications (RTP) (240 Channels)
6800	TCP	To LAN (3300s)	MiNet
6801	TCP	To LAN (3300s)	MiNet (Secure)
6802	TCP	To LAN (3300s)	MiNet (Secure)
6803	TCP	To LAN (3300s)	Trusted Services (Secure)
6809	UDP	To/From LAN	Redhat Cluster (NuPoint 640 Configurations only)
8000	TCP	To LAN (3300s)	MiTAI
8001	TCP	To LAN (3300s)	MiTAI (SSL)
8005	TCP	Internal	Tomcat shutdown
8009	TCP	Internal	Client Server Tomcat
8080	TCP	From LAN	HTTP/Tomcat
<p>Note: Prior to Release 6.0, NuPoint used ports 50,000 to 50,479 for RTP (voice) streaming. For NuPoint Release 6.0 and later, the start port for RTP streaming by default is 50,000; however, the start port can be changed by the MSL database in order to avoid conflict with vUCC.</p> <p>NuPoint reads the starting port for RTP streaming from the MSL database. If the starting point in MSL is 50,000, the port range will be 50,000 to 51,440, since NuPoint supports a maximum of 240 channels and six ports are required for each channel. Please note that a channel equates to one softphone in NuPoint.</p>			

APPENDIX B – NUPOINT-MIB MODULE DESCRIPTION

The proprietary MIB files can be compiled into the network management system (NMS) that is being used to manage your NuPoint UM system.



Note: You can copy the following proprietary MIB definitions for NuPoint and package the files with a *.smi extension. Bear in mind, however, that creating files in this manner may result in a "copy and paste" error which will prevent the NMS from being able to parse to the MIB definitions for NuPoint.

TRAPSSMI.SMI

```
-- trapsmi.smi
-- MIB for traps, trap filters and trap variables

-- Centigram MIB extension for VoiceMemo software

.. *****
-- Implementation Version
-- 09/04/1996 Edward Shu
-- 06/15/1995 Chang Xu
-- Centigram Communications
.. *****
#include "ode/objids.smi"
#include "ode/types.smi"

VM-MIB DEFINITIONS ::= BEGIN

IMPORTS
    OBJECT-TYPE
        FROM RFC-1212
    enterprises
        FROM RFC1155-SMI;

-- groups in VMA-MIB
--

centigram    OBJECT IDENTIFIER ::= { enterprises 1096 }
series6cs    OBJECT IDENTIFIER ::= { centigram 1 }
vm-mib       OBJECT IDENTIFIER ::= { series6cs 1 }
ctrap        OBJECT IDENTIFIER ::= { vm-mib 1 }
trapCommon   OBJECT IDENTIFIER ::= { ctrap 1 }
```

trapFilter OBJECT IDENTIFIER ::= { ctrap 2 }

--
-- Trap text string
--

errCode OBJECT-TYPE
SYNTAX OCTET STRING (SIZE (5))
ACCESS read-only
STATUS mandatory
DESCRIPTION
"Error category information among the managed objects of Centigram's Software."
::= { trapCommon 1 }

errSeverity OBJECT-TYPE -- consistent with "trapcode.h"
SYNTAX INTEGER {
critical (3), -- Red, serious problem
major (5), -- Dark Red, degradation of operation
minor (7), -- Orange, some device degradation
warning (9), -- Yellow, potential course of problem
informational (11), -- Magenta, informational message
normal (13), -- Green, normal state
unknown (15), -- Blue, device doesnot report status
everything (20) -- used only for threshold
}
ACCESS read-only
STATUS mandatory
DESCRIPTION
"Error severity. See HP OpenView's Definition"
::= { trapCommon 2 }

errBriefDes OBJECT-TYPE
SYNTAX OCTET STRING (SIZE (0..119))
ACCESS read-only
STATUS mandatory
DESCRIPTION
"Brief description of the nature and course of the error."
::= { trapCommon 3 }

errDetailDes OBJECT-TYPE
SYNTAX OCTET STRING (SIZE (0..119))
ACCESS read-only

STATUS mandatory

DESCRIPTION

"Detail description of the nature and course of the error."

::= { trapCommon 4 }

errLocation OBJECT-TYPE

SYNTAX OCTET STRING (SIZE (0..63))

ACCESS read-only

STATUS mandatory

DESCRIPTION

"Where the error occurred."

::= { trapCommon 5 }

errTimeStamp OBJECT-TYPE

SYNTAX OCTET STRING (SIZE (0..31))

ACCESS read-only

STATUS mandatory

DESCRIPTION

"When the error occurred."

::= { trapCommon 6 }

errParamList OBJECT-TYPE

SYNTAX OCTET STRING (SIZE (4))

ACCESS read-only

STATUS mandatory

DESCRIPTION

"Indicate the error parameters, such as Module:Slot:Port for linecard error."

::= { trapCommon 7 }

--
-- Trap filters, configurable to specify which category of traps to be sent
-- and come from which module or with which severity level

--
moduleIDFilter OBJECT-TYPE

SYNTAX INTEGER {

module1 (1),

module2 (2),

module2_1 (3),

module3 (4),

module3_1 (5),

module3_2 (6),

```
    module3_2_1 (7),
    module4 (8),
    module4_1 (9),
    module4_2 (10),
    module4_2_1 (11),
    module4_3 (12),
    module4_3_1 (13),
    module4_3_2 (14),
    all_modules (15)
}
ACCESS read-write
STATUS mandatory
DESCRIPTION
    "Specify which modules should send traps."
::= { trapFilter 1 }
```

severityFilter OBJECT-TYPE

```
SYNTAX INTEGER {
    none (1),
    critical (3),
    critical_up (4),
    major (5),
    major_up (6),
    minor (7),
    minor_up (8),
    warning (9),
    warning_up (10),
    informational (11),
    informational_up (12),
    normal (13),
    everything (20)
}
ACCESS read-write
STATUS mandatory
DESCRIPTION
    "Specify which severity traps should be sent."
::= { trapFilter 2 }
```

messagetypeFilter OBJECT-TYPE

```
SYNTAX INTEGER {
    error (1),
    debug (2),
    reference (3),
```

```

        all_messages (4)
    }
    ACCESS read-write
    STATUS mandatory
    DESCRIPTION
        "Specify which error type should send traps."
    ::= { trapFilter 3 }

```

```

subsystemFilter OBJECT-TYPE
    SYNTAX OCTET STRING (SIZE (0..31))
    ACCESS read-write
    STATUS mandatory
    DESCRIPTION
        "Specify which sub system should send traps."
    ::= { trapFilter 4 }

```

```

-- General Trap
generalCritical TRAP-TYPE
    ENTERPRISE   ctrap
    VARIABLES    { errCode, errSeverity, errBriefDes,
                  errDetailDes, errLocation, errTimeStamp, errParamList }
    DESCRIPTION
        "A process report Critical error."
    ::= 1

```

```

generalMajor TRAP-TYPE
    ENTERPRISE   ctrap
    VARIABLES    { errCode, errSeverity, errBriefDes,
                  errDetailDes, errLocation, errTimeStamp, errParamList }
    DESCRIPTION
        "A process report Major error."
    ::= 2

```

```

generalMinor TRAP-TYPE
    ENTERPRISE   ctrap
    VARIABLES    { errCode, errSeverity, errBriefDes,
                  errDetailDes, errLocation, errTimeStamp , errParamList }
    DESCRIPTION
        "A process report Minor error."
    ::= 3

```

```

generalWarning TRAP-TYPE
    ENTERPRISE   ctrap

```



```
VARIABLES    { errCode, errSeverity, errBriefDes,
               errDetailDes, errLocation, errTimeStamp , errParamList}
DESCRIPTION
    "A process report Warning error."
 ::= 4
```

generalInformational TRAP-TYPE

```
ENTERPRISE   ctrap
VARIABLES    { errCode, errSeverity, errBriefDes,
               errDetailDes, errLocation, errTimeStamp , errParamList}
DESCRIPTION
    "A process report Informational error."
 ::= 5
```

generalNormal TRAP-TYPE

```
ENTERPRISE   ctrap
VARIABLES    { errCode, errSeverity, errBriefDes,
               errDetailDes, errLocation, errTimeStamp , errParamList}
DESCRIPTION
    "A process report Normal error."
 ::= 6
```

END

OBJID.SMI

```
--SCCS*****
--scs Audit trail generated for Peer scs tracking
--scs module objids.smi, release 1.5 dated 92/07/25
--scs retrieved from /home/peer/ame/common/ode/include/SCCS/s.objids.smi
--scs
--scs 1.5      92/07/25 16:05:22 randy
--scs  remove character that chokes microsoft compiler
--scs
--scs 1.4      92/03/16 20:19:19 randy
--scs  added PEER's internet arc
--scs
--scs 1.3      92/02/05 17:20:41 randy
--scs  protect against re-inclusion
--scs
--scs 1.2      91/09/21 17:39:48 timon
--scs  added PEER's registration arc
--scs
```

```
--scs 1.1      91/09/07 16:30:55 timon
--scs  date and time created 91/09/07 16:30:55 by timon
--scs
--scs
--scs*****/
#endif ODE_OBJIDS_SMI
#define ODE_OBJIDS_SMI
ObjectIds DEFINITIONS ::= BEGIN
internet  OBJECT IDENTIFIER ::= { iso(1) org(3) dod(6) 1 }
directory OBJECT IDENTIFIER ::= { internet 1 }
mgmt      OBJECT IDENTIFIER ::= { internet 2 }
experimental OBJECT IDENTIFIER ::= { internet 3 }
private   OBJECT IDENTIFIER ::= { internet 4 }
enterprises OBJECT IDENTIFIER ::= { private 1 }
--
--      Peer Networks has two registered arcs:
--          one assigned by ANSI
--          another assigned by internet
--
--      The internet arc is used exclusively for SNMP stuff, as a crutch for
--      those SNMP managers that can't deal with real object ids.
--
peer-networks OBJECT IDENTIFIER ::= { iso(1) national-body(2) usa(840) 113558 }
peer          OBJECT IDENTIFIER ::= { enterprises 442 }
--
--      Within the 'peer' arc, entire subtrees are dedicated to the following:
--
peer-products OBJECT IDENTIFIER ::= { peer 1 }
peer-demos    OBJECT IDENTIFIER ::= { peer 2 }
END
#endif
```

TYPES.SMI

```
--scs*****
--scs Audit trail generated for Peer sccs tracking
--scs module types.smi, release 1.3 dated 92/03/16
--scs retrieved from /home/peer/ame/common/ode/include/SCCS/s.types.smi
--scs
--scs 1.3      92/03/16 20:19:31 randy
--scs  included standard snmp type definitions
--scs
--scs 1.2      92/02/05 17:20:52 randy
--scs  protect against re-inclusion
--scs
--scs 1.1      91/09/21 17:24:45 timon
--scs  date and time created 91/09/21 17:24:45 by timon
--scs
--scs
--scs*****/
```

```
#ifndef ODE_TYPES_SMI
#define ODE_TYPES_SMI
```

```
STANDARD-COMPLEX-TYPES DEFINITIONS ::= BEGIN
```

```
--
--      from RFC 1213 (MIB II)
--
-- textual conventions
```

```
DisplayString ::=
    OCTET STRING
```

```
-- This data type is used to model textual information taken
-- from the NVT ASCII character set.  By convention, objects
-- with this syntax are declared as having
--
--      SIZE (0..255)
```

```
PhysAddress ::=
    OCTET STRING
-- This data type is used to model media addresses.  For many
-- types of media, this will be in a binary representation.
-- For example, an ethernet address would be represented as
-- a string of 6 octets.
```

```
--  
--      From the SNMP RFC 1157  
--  
ObjectName ::= OBJECT IDENTIFIER  
  
IpAddress ::= [APPLICATION 0] IMPLICIT OCTET STRING  
  
Counter  ::= [APPLICATION 1] IMPLICIT INTEGER -- (0..4294967295)  
  
Gauge    ::= [APPLICATION 2] IMPLICIT INTEGER -- (0..4294967295)  
  
TimeTicks ::= [APPLICATION 3] IMPLICIT INTEGER -- (0..4294967295)  
  
Opaque   ::= [APPLICATION 4] IMPLICIT OCTET STRING  
  
NetworkAddress ::= IpAddress  
  
END  
  
#endif
```

